

Strengthening Open-Web Steel Joists

JAMES M. FISHER

This paper was presented at the 2004 North American Steel Construction Conference.

The purpose of this paper is to present procedures and suggested details for the strengthening of open web steel joists. Strengthening of open web steel joists is often required due to the addition of rooftop units, underhung conveyors, or other loading increases not contemplated in the original specification for the joists.

There are three basic methods of strengthening a joist or a joist system for additional loading:

1. Load redistribution.
2. Adding new joists or beams.
3. Reinforcing existing joists.

EXISTING JOIST CAPACITY

The first step in determining if a joist system requires strengthening is to determine the existing joist capacity. This can be done using the Steel Joist Institute (SJI) Load Tables, which are contained in the *SJI 75-Year Steel Joist Manual* (SJI, 2003). The SJI Specifications for all joists manufactured from 1928 to 2003 are contained in the digest. The Specification requirements for web member capacity are especially useful (H joists web members were designed for a minimum of 50% of the end reaction; whereas, K series joists are only designed for a minimum of 25% of the end reaction). If historical data regarding the joist system are unavailable then detailed field measurements of chord and web members will be required to calculate the joist capacity. If the applicable joist specification year can be determined, the specifications and joist load tables can be used to determine shear and moment envelopes. If the joist load tables cannot be used, then an analysis to determine the allowable (ASD) or design (LRFD) forces in the joists is required.

James M. Fisher is vice president, Computerized Structural Design, Milwaukee, WI.

The SJI Specifications, for K-series joists, permits eccentricities at the chord joints to be neglected in the analysis, provided that the “ $\frac{3}{4}$ rule” is followed. This rule comes from Section 4.5(d) of the *SJI Standard Specifications for Open Web Steel Joists, K-Series* (SJI, 2005).

From the Specification, “Members connected at a joint shall have their centroidal axes meet at a point if practical. Otherwise, due consideration shall be given to the effect of eccentricity. In no case shall eccentricity of any web member at a joint exceed $\frac{3}{4}$ of the overall dimension, measured in the plane of the web, of the largest member connected. The eccentricity of any web member shall be the perpendicular distance from the centroidal axis of that web member to the point on the centroidal axis of the chord which is vertically above or below the intersection of the centroidal axes of the web members forming the joint.” The SJI Specifications for LH-series joists, DLH-series joists, and Joist Girders prescribe that, “Eccentricity on either side of the neutral axis of chord members may be neglected when it does not exceed the distance between the neutral axis and the back of the chord.” The SJI Specification for K-series joists permits bending moments to be neglected in the top chord, provided the panel point spacing does not exceed 24 inches. These analysis and design assumptions have been proven conservative by hundreds of tests conducted through the years by joist suppliers.

The author suggests that when analyzing joists (a first-order linear analysis is adequate) with the reinforcing members, that the following criteria be used in the model:

1. Include joint eccentricities when greater than those allowed by the SJI.
2. Include top chord moments in the design, even when the panel points are less than 24 in. apart.
3. Use pinned connections at the web member ends as is the case for the design of standard joists.

Item 2 is suggested since reinforced joists do not have the benefit of being tested to validate design and analysis assumptions.

Before deciding which method of reinforcing is appropriate, the designer should obtain as much information about the joist system to be reinforced as possible. This normally requires a trip to the site or is obtained from detailed information from the client. Helpful and required information include the following:

- Year of construction.
- The joist manufacturer.
- Loading on the joists (roof, floor, other).
- Information from joist tags.
- Joist configuration (Warren, modified Warren, Pratt, other).
- Joist span.
- Joist spacing.
- Joist depth.
- Seat depths.
- Seat bearing condition (top or bottom).
- Type of web members (obtain dimensions including thicknesses):
 - a. Rod webs (usually K and H-series < 24 in. deep).
 - b. Crimped webs (usually K and H-series > 24 in. deep).
 - c. Angles welded to the outside of the chords (some LH and Joist Girders).
 - d. Cold-formed sections.
 - e. End diagonal type.
 - f. Eccentricities.
 - g. Panel point spacing.
- Type of chords (obtain dimensions including thicknesses, and separation distance):
 - a. Double angles.
 - b. Cold formed sections.
 - c. Rods.
 - d. Splices.
- Type of bridging and locations.

- Quality of bridging connections.
- Anchorage of bridging.
- Interferences.
- Condition of joists.
- Coupon samples from chords and web members to determine yield strength if not known.

The joist tag may give information regarding the manufacturer and the size of the joist. If member sizes are measured in the field, a micrometer must be used, since material thicknesses are provided by joist manufacturers in thousandths of an inch.

LOAD REDISTRIBUTION

Load redistribution is a method of distributing concentrated loads to several joists in a joist floor or roof system. Load redistribution is an option if a member can be placed under or through the joist as shown in Figure 1. If the inserted member has suitable stiffness, the concentrated load can be distributed to several joists. The equation below can be used to determine if the force shown in Figure 1 can be distributed to the joists using static equilibrium (Nucor, 2002).

The relative stiffness of the joists, and the distribution beam, is defined by the characteristic parameter beta:

$$\beta = \sqrt[4]{\frac{(K/S)}{(4E/I)}}$$

where

- K = the stiffness of the joist, kips/in.
- S = the spacing of the joists, in.
- E = the modulus of elasticity for the beam, ksi
- I = the moment of inertia of the beam, in.⁴

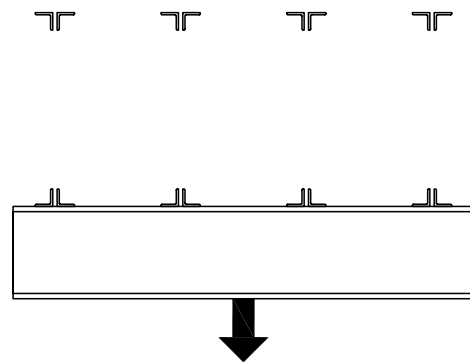

Fig. 1. Load distribution.

If S is less than $\pi/4\beta$, the spacing limit is not exceeded, and the length of the beam is less than $1/\beta$, the beam may be considered to be rigid with respect to the supporting joists, and the reactions to the joists may be determined by static equilibrium.

If the criteria are not satisfied, strength of material solutions for beams on elastic foundations can be used to determine the reactions to the joists, or a computer solution can be used where the distribution beam is modeled and the joists are modeled as springs to determine the load distribution. In lieu of a beam as shown in Figure 1, it may be possible to add the beam, or a truss system, through the joists openings to distribute load.

ADDING NEW JOISTS OR BEAMS

Consider adding new joists or wide flange beams to support added loads before using expensive reinforcement solutions. Of major concern in adding joists or beams are existing interferences. It may not be practical to add members because piping, electrical conduits, or other interferences may have to be removed or relocated at a greater expense than reinforcing.

If joists are to be added, consideration must be given to camber. To insert the joists or beam in place, "no camber" should be specified for the added joists. For situations involving K-series joists, seat depths should be ordered to a 2 in. height and then shimmed to facilitate erection. A preferred way to provide supplemental joists is to have the joist manufacturer provide a center splice, so that two individual pieces can be installed and then bolted at the center.

REINFORCING EXISTING JOISTS

The type of reinforcement, and details to be used, are dependent on the geometry of the joist to be strengthened. The following items have a major impact on the solution for both chord and web reinforcement:

1. Rod web members.
2. Crimped angle web members (many crimped web joists have rod end diagonals)
3. Web angles welded to the sides of the chords.
4. Geometry of the chords.
5. Chord and web yield strength.

Consider also that it may be possible to reinforce the chords and web members on only one side. This may be required when joists are adjacent to walls or other interferences. Particular attention must then be paid to eccentricities.

Design Approaches

There are two design approaches with respect to reinforcing joists.

Approach I: Ignore the existing strength of the members.

Approach II: Make use of the strength of the existing member.

Although Approach I is conservative, it avoids load distribution concerns between the reinforcing member and the existing member. This approach is not generally used for chord reinforcement.

When using either approach, consider the fact that the cost of materials for reinforcing is almost insignificant compared to the cost of the field labor.

Also, with either design approach, it is safest to reinforce the joist in the shored position. Welding can generate enough heat to cause a temporary loss of strength in the steel. This is particularly true if welds are made transverse to the axis of the member. With the loss of strength the member can sag excessively or even collapse, thus shoring should be placed tight against the joist being reinforced. It is also best to reinforce members with the dead and live loads removed. This can be done by calculating the amount of load present on the joist and then jacking the joist up to a calculated deflection that theoretically removes the load on the joist. In most cases, jacks located at the third points should be used.

The designer is also cautioned to pay particular attention to eccentricities created by the reinforcing, and also to account for any shear lag effects in the design.

Approach I

If Approach I is used, there are no special considerations that need to be addressed. Simply design the reinforcing members to carry the total load.

Approach II

For Approach II, it is assumed that applied forces are distributed between the existing member and the reinforcing member in direct proportion to their areas. Any preload force in the existing member must be considered. If the joists are shored and jacked up to remove the existing load, then the preload is zero, otherwise the preload can be calculated based on the load present at the time of reinforcing.

Design Procedure

Terminology and Variables

Composite section. Combined existing member and reinforcing member.

Preload force. Force in the existing member not removed by shoring.

End welds. Welds at the ends of an existing member or the reinforcing member.

Existing member. The member originally supplied in the joist or joist girder

Reinforcing member. The added member(s).

Required force. The total force to be carried by the chord or web member.

- A_e = area of existing member.
- A_r = required area of reinforcing.
- A_{rf} = area of the furnished reinforcing.
- A_t = total area required (existing member and required reinforcing).
- F_{ye} = specified minimum yield stress of existing member.
- P_o = original force for the existing member (original design force).
- P_p = preload in the existing member at the time of reinforcing.
- P_r = force in the reinforcing member.
- P_t = required force.
- P_{rw} = required force in the reinforcing member weld.
- f_p = stress from preload in the existing member.

Design of Reinforcing for Tension Members (Approach II)

1. Determine the total area required, A_t .

If the force in the existing member is limited to the original required force in the member, the following equation applies. Using this procedure, the initial welds, as provided by the joist manufacturer, are not increased.

$$P_p + (P_t - P_p) \left(\frac{A_e}{A_t} \right) \leq P_o$$

thus

$$A_t = \frac{(P_t - P_p)}{(P_o - P_p)} A_e$$

2. The required area of reinforcing equals

$$A_r = A_t - A_e$$

3. The force in the reinforcing member equals

$$P_r = \left(\frac{A_{rf}}{A_t} \right) (P_t - P_p)$$

Alternately, the weld on the existing member can be reinforced to take the entire axial load, provided an adequate force path exists to transfer the force in the reinforcing member to the weld.

As an alternate to the above, for tension members only, an ultimate strength approach could be used, wherein, the yield strength of the composite section is used to resist the tension load.

Design of Reinforcing for Compression Members (Approach II)

1. Select a trial reinforcing member.
2. Check the buckling strength of the composite member. If a preload force exists, first determine the magnitude of the compressive stress in the existing member due to the preload, f_p . For the buckling check, use F_y as the minimum of $(F_{ye} - f_p)$, and F_y of the reinforcing member.
3. Design the weld for the reinforcing member. The force in the weld is

$$P_{rw} = \left(\frac{A_{rf}}{A_t} \right) (P_t - P_p)$$

Or as previously mentioned, the weld on the existing member can be reinforced to take the entire axial load, provided an adequate force path exists to transfer the force in the reinforcing member to the weld.

Chord Reinforcement

Shown in Figures 2a through 2f are several details that have been used to reinforce top chords of joists. Because roof or floor deck is usually in place and interferes with the placement of reinforcement and welding, top chord reinforcement presents a bigger erection challenge than bottom chord reinforcement. For joists where the web members are attached to the outside of the vertical legs of the chords (see Figure 5), the web members are often tight against the outstanding chord legs. In this case the details shown in Figures 2a through 2d will probably not work. However, the details shown in Figures 2e or 4 could be used. The detail shown in Figures 2c will not generally work for joists but can work in some cases for joist girder reinforcement where down hand welds can be made. The overhead welds required for the reinforcing angle legs closest to the chord web in Figure 2c is difficult, unless there is enough clearance for the electrode to be positioned at a 45-degree angle. If splicing of the rounds is required, consider the splice detail shown in Figure 2f. The splice can be made in the shop or in the field and then lifted into place.

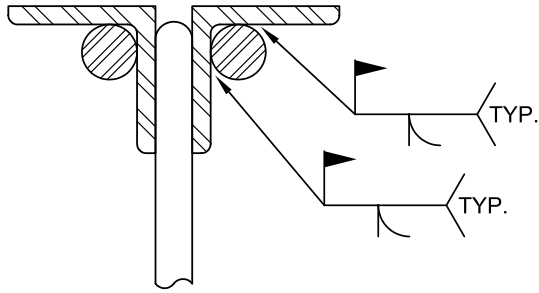

Fig. 2a. Top chord reinforcement—rods.

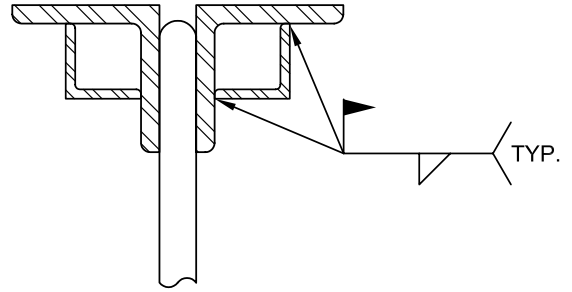

Fig. 2d. Top chord reinforcement—angles.

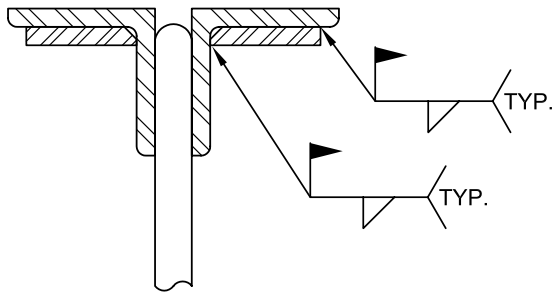

Fig. 2b. Top chord reinforcement—plates.

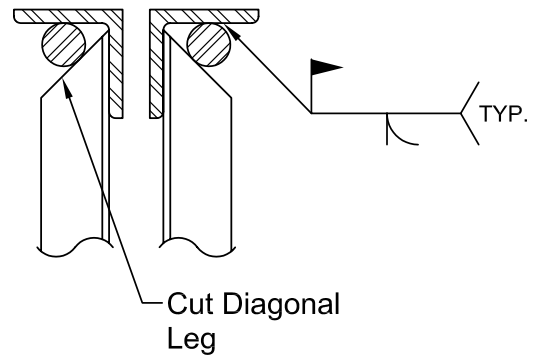

Fig. 2e. Top chord reinforcement—rods.

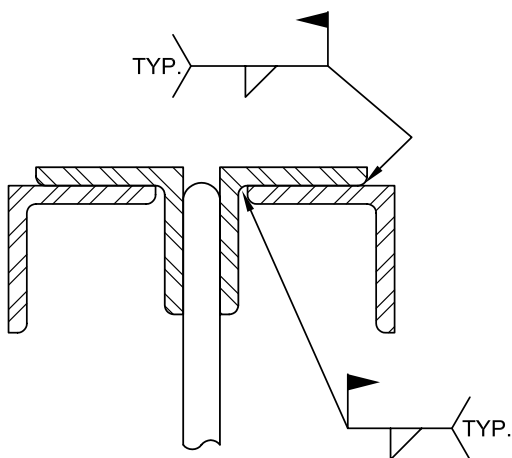

Fig. 2c. Top chord reinforcement—angles.

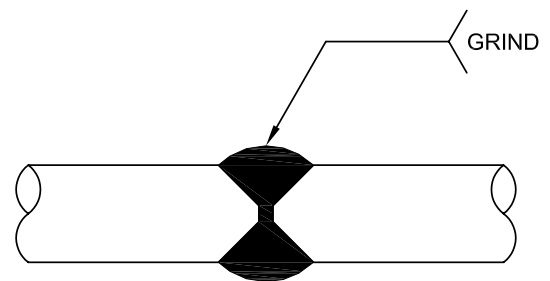

Fig. 2f. Rod splice.

Bottom chord reinforcement is usually accomplished as shown in Figure 3, or by using rods as shown for top chord reinforcing in Figures 2a through 2f. Rods are more often available in longer lengths than plate, which may eliminate the need for a butt splice. If the same size rods are used for the bottom chord as used for the top chord, costs may be saved because one less material size needs to be procured. On occasion, the detail shown in Figure 4 may be required for either top or bottom chords.

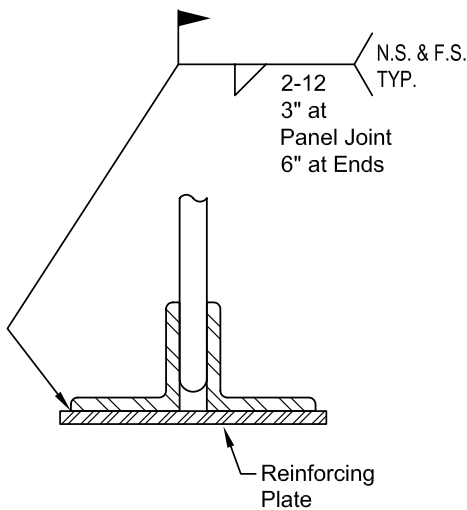

Fig. 3. Bottom chord reinforcement.

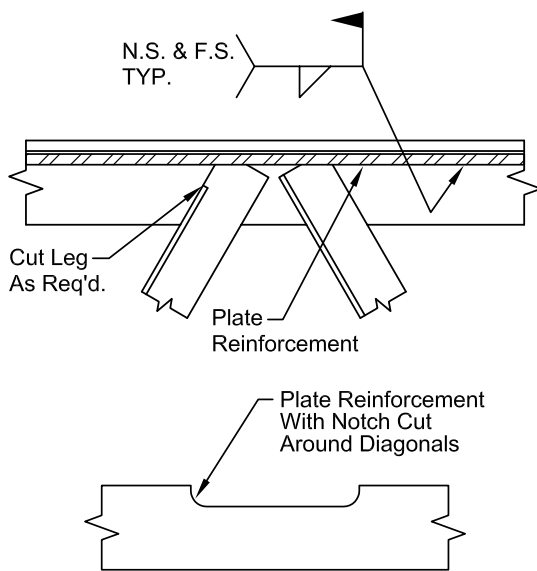

Fig. 4. Chord reinforcement requiring notch.

There are no direct rules as to the maximum size of chord reinforcing members. Shear transfer from the existing chord to the reinforcing member must be checked. Sufficient weld must be made at the panel points to transfer the required forces into the existing chord and into the chord reinforcement.

Web Reinforcement

Rod Web Members

Joists with rod webs are the easiest to reinforce, since the webs do not interfere with chord reinforcement and the reinforcing web diagonals can be welded to the chords directly. If the top chord requires reinforcement the reinforcing may reduce the available length of the end weld for web members (see Figure 6). The top chord must be checked for block shear.



Fig. 5. Angles interfering with top chord reinforcement.

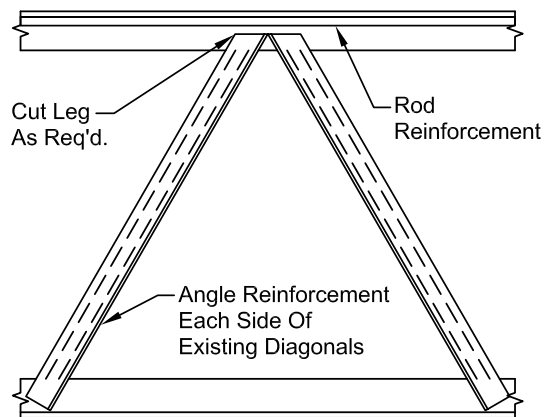

Fig. 6. Angle reinforcement on rod web joist.

Crimped Angle Web Members

Shown in Figure 7 is a joist with crimped angle web members. Notice how the web member protrudes beyond the vertical leg of the top chord. This prevents placing a new web member directly alongside and welding to the chord leg.



Fig. 7. Joist with crimped web members.

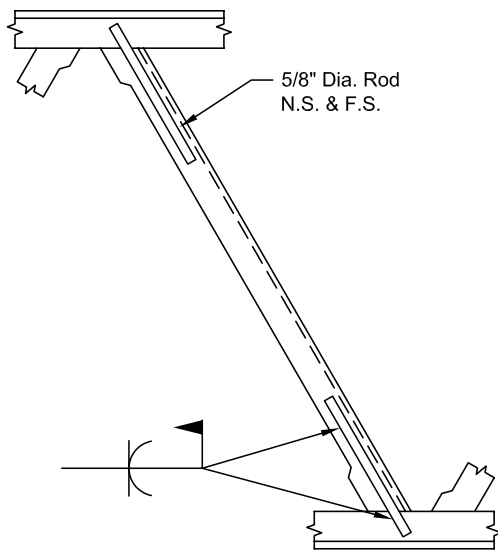

Fig. 8. Weld-only reinforcement.

Shown in Figure 8 is a method of reinforcing the welded joints of crimped angle web members. A round can be laid adjacent to the chords and the web, and flare bevel welds can be used to transfer the loads from the web member. Shown in Figure 9 is the condition where the web member requires additional reinforcement. The strength of the existing crimped web angle can be added to the plate strength provided the weld is capable of transferring the entire load to the chord. Shown in Figures 10 through 13 are alternate details for reinforcing crimped angle web members.

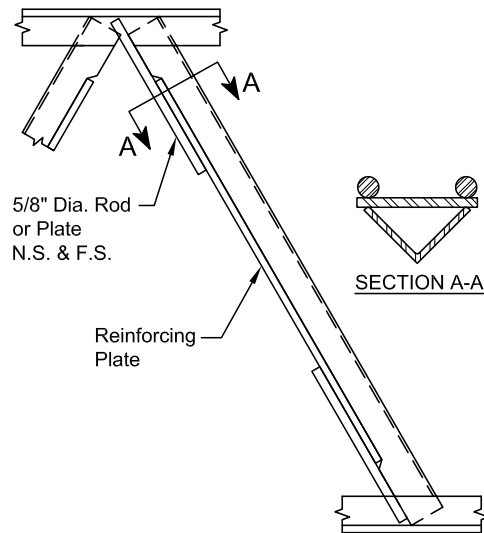

Fig. 9. Crimped web reinforcement.

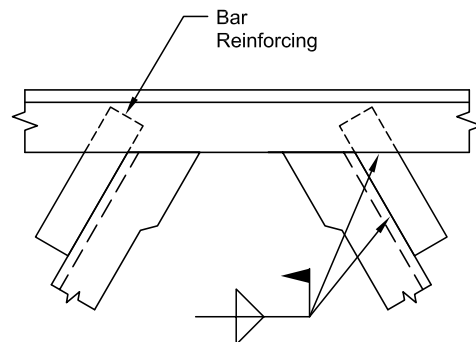

Fig. 10. Reinforcing diagonals.

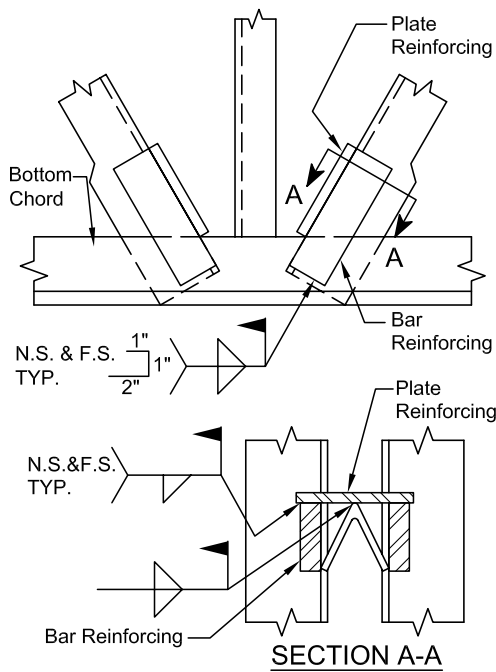

Fig. 11. Reinforcing diagonals.

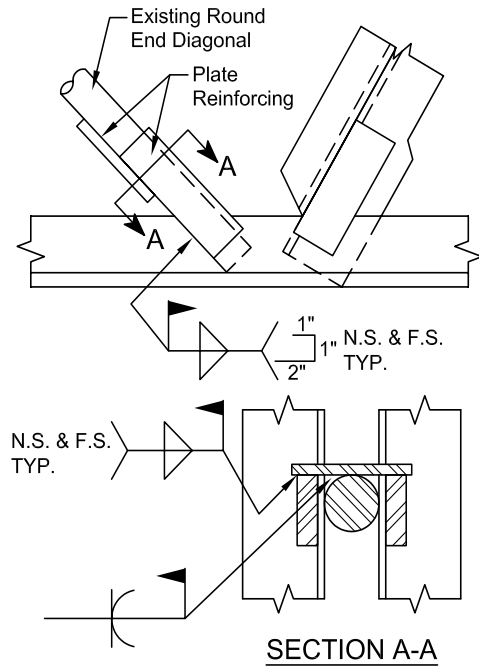

Fig. 13. Channel reinforcing at end diagonal

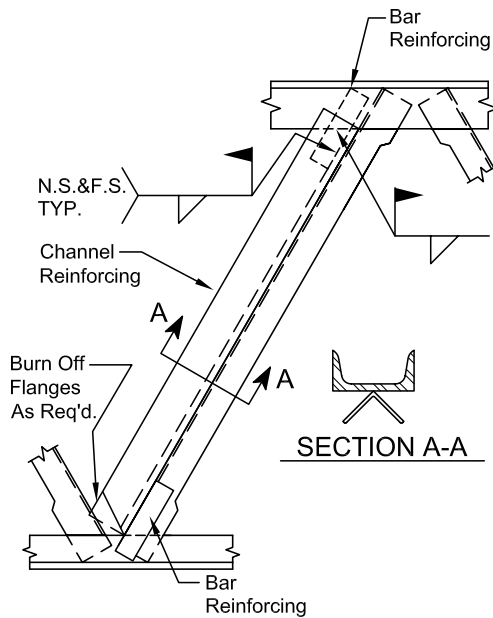

Fig. 12. Channel reinforcing.



Fig. 14. Web angles on side of chords.

Web Angles Welded to the Sides of the Chords

A photo illustrating web angles welded to the sides of a chord is shown in Figure 14. Illustrated in Figure 15 is reinforcement added to the web member. End weld may have to be added to the existing angles to transfer the load from the reinforcing into the chord. Usually this weld can be added to the heel of the existing angle. Gussets may also be added as shown in Figure 16. Fillers, if required, must be developed. If the chord thickness is $\frac{3}{16}$ in. or less, the weld can be built-up, and fillers are not required.

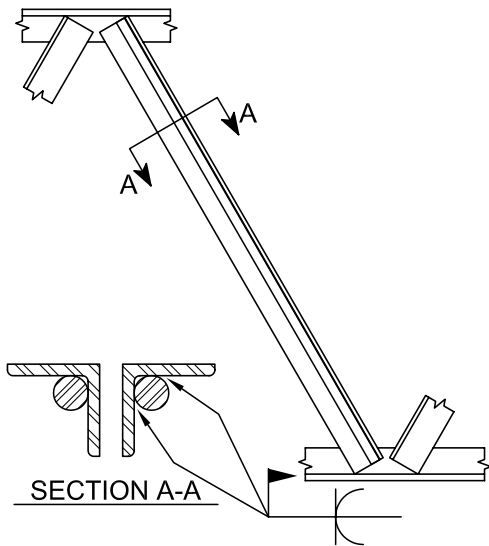

Fig. 15. Rod reinforcing.

End Diagonals

Examples of reinforcing on end diagonals are shown in Figures 17 and 18.

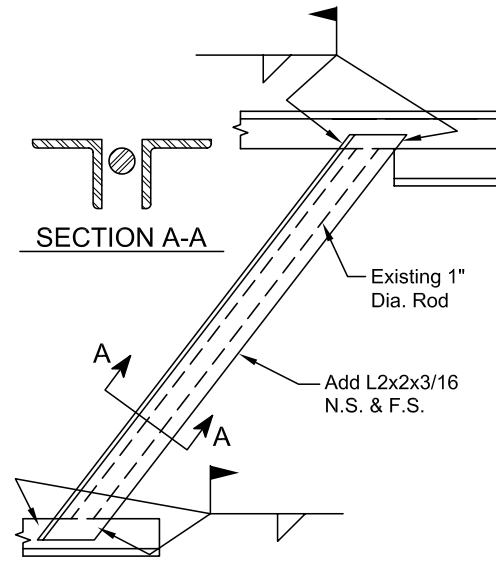

Fig. 17. Angles and welds added.

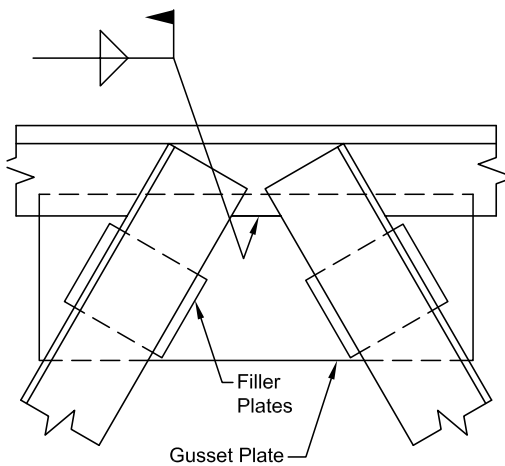

Fig. 16. Added gusset plate for weld requirements.

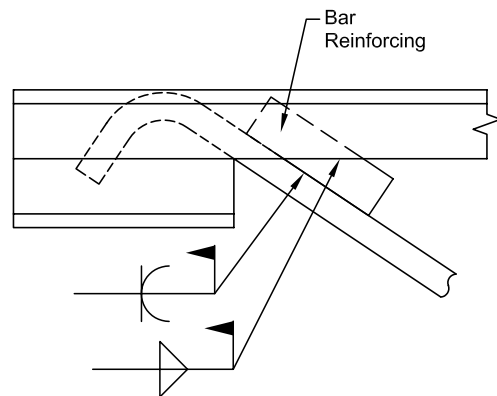

Fig. 18. Bar added for additional weld.

EXAMPLE

The following example illustrates the chord reinforcing of K-series open web joists. The original joists were designated as 24K Special. This example was taken from an actual situation where roof joists required reinforcement to support new conveyor loads in an existing warehouse. The new conveyors were supported off of the joist bottom chords. Shown in Figure 19 is a typical joist loading diagram. The uniform loads shown along the top chord are the original design loads. The concentrated loads shown along the bottom chord are the new conveyor loads. Approximately 750 joists were affected by this new loading. Certain web members also required reinforcement. The same approaches as shown in this example for the chords can be applied to the reinforcement of the web members.

The load distribution method of verifying steel joists was not a feasible solution since the spreader beams would interfere with the conveyor system. Due to other interferences, adding new joists or beams was not possible. Joist reinforcing was the only solution. A check of a worst-case scenario indicated that top and bottom joist chords were approximately 40% overstressed.

The joist considered in this example has a design span that equals 41 ft 7½ in. and a total depth of 24 in. The panel points are 24 in. on center. The top and bottom chords are double angles. The top chord angles are L2 in. x 2 in. x ¾ in., and the bottom chord angles are L1.75 in. x 1.75 in. x 0.150 in. The webs are crimped single angles, except for the end diagonals, which are round bars. The yield strength, F_y , equals 50 ksi for all members in the joists. The required axial force in the top chord is 35.2 kips, and the allowable top chord force was obtained from the joist manufacturer and is 29.6 kips. The bottom chord required force is 35.2 kips. The

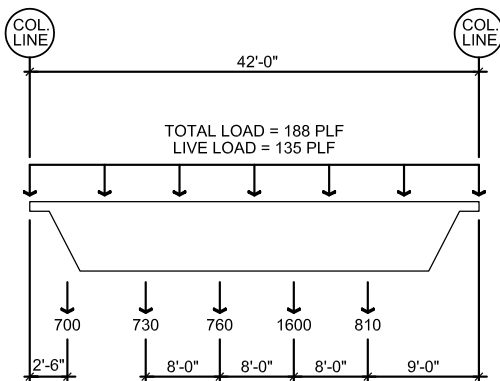

Fig. 19. Joist loading.

allowable load is 28.4 kips. The load in the chords at the time of reinforcing is 6.2 kips (dead load). Since the joists were originally designed using ASD, those same procedures were used to determine the required reinforcement. Approach II was used.

Top Chord Reinforcing

Design Approach:

1. Select a trial reinforcing member.
2. Determine the composite section properties of the reinforcing member and the existing member.
3. Check overall chord buckling. First determine the magnitude of the compressive stress in the existing member due to the preload, f_p . For the buckling check, use F_y as the minimum of $(F_{ye} - f_p)$, and F_y of the reinforcing member.
4. Design the weld size and length for the reinforcing member. The force in the weld is

$$P_{rw} = \left(\frac{A_{rf}}{A_t} \right) (P_t - P_p)$$

5. Check local buckling of the reinforcing.

Solution:

1. Trial member: Try using two ¾-in.-diameter rods, $F_y = 36$ ksi.
2. Determine the composite properties of the combined section shown in Figure 20:

The total area,

$$A_t = \Sigma A_c$$

$$\begin{aligned} \text{Area of the existing top chord angles} &= 2(0.713) \\ &= 1.426 \text{ in.}^2 \end{aligned}$$

$$A_t = \Sigma A_c = 1.426 + 2(0.442) = 2.31 \text{ in.}^2$$

The location of the centroid is

$$\begin{aligned} \bar{y} &= \frac{1}{A} \Sigma A_i \bar{y}_i = \frac{1}{2.31} [2(0.713)(0.569) \\ &\quad + 2(0.442)(0.1875 + 0.375)] \end{aligned}$$

$$= 0.566 \text{ in.}$$

The moment of inertia is

$$I = \sum I_i + A_i d_i^2$$

$$= 2[(0.272 + 0.016) + 0.713(0.509 - 0.566)^2 + 0.442(0.563 - 0.566)^2]$$

$$I = 0.576 \text{ in.}^4$$

The radius of gyration is

$$r = \sqrt{\frac{I}{A_t}} = 0.499 \text{ in.}$$

3. Check chord buckling:

For the top chords, the allowable load is determined using the AISC Specification (AISC, 1989):

$$P_c = F_a A_t$$

where

- P_c = allowable compression, kips
- A_t = member cross-sectional area, in.²
- F_a = allowable compressive stress, ksi

$$\text{if } \frac{L}{r} \leq C_c$$

$$F_a = \frac{\left[1 - \left(\left(\frac{L}{r}\right)^2 / C_c^2\right)\right] Q F_y}{\frac{5}{3} + \frac{3}{8} \left(\frac{L}{C_c}\right) - \frac{1}{8} \left(\frac{L}{C_c}\right)^3}$$

where

$$C_c = \sqrt{\frac{2\pi^2 E}{Q F_y}}$$

$$\text{if } \frac{L}{r} > C_c$$

$$F_a = \frac{12\pi^2 E}{23(KL/r)^2}$$

Compute the slenderness ratio. The vertical web members provided between the panel points brace the chord. Use an unsupported length $L = 24$ in.

$$\frac{L}{r} = \frac{24}{0.499} = 48$$

Determine a yield stress to be used for the reinforcement design:

Preload, $P_p = 6.2$ kips

$$f_p = \frac{6.2}{(2)(0.713)} = 4.35 \text{ ksi}$$

Yield stress is the minimum of $F_{ye} - f_p = 50 - 4.35 = 45.65$ ksi, and $F_y = 36$ ksi for the rods. Thus, use 36 ksi.

Q for the angles = 1.0, $C_c = 126.1$.

The allowable compressive axial stress is

$$F_a = 18.53 \text{ ksi}$$

And, the allowable compressive force equals

$$P_c = (18.53)(2.31) = 42.8 \text{ kips}$$

> 35.2 kips required o.k.

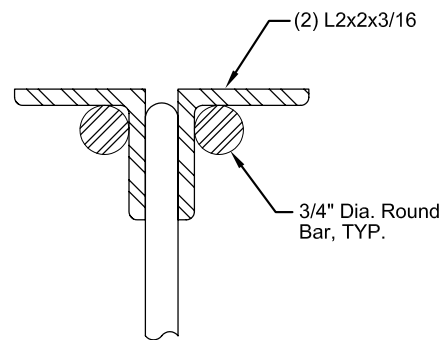

Fig. 20 Composite section.

4. Design the welds:

The welds to be used are shown in Figure 21. Since the panel points are 24 in. apart, rather than showing the welds as stitch welds, it may be clearer to the erector to call for 2 in. of weld at each mid-panel.

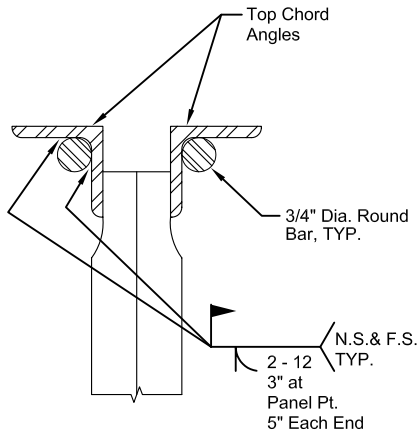

Fig. 21 Top chord reinforcement.

Each of the 3/4-in.-diameter rods has an allowable force of $(18.53)(0.44) = 8.15$ kips.

The effective throat of each weld equals $(5/16)$ times the rod radius, thus the effective throat equals 0.117 in. Using E70 electrodes the allowable shear per weld equals $(0.117 \text{ in.})(21 \text{ ksi}) = 2.46$ kips/in. The total length of weld required to develop the force in each rod equals $8.15/2.46 = 3.31$ in. The 10 in. of weld shown in Figure 21 is more than adequate. The 3 in. at each panel point is sufficient to transfer the force into the reinforced composite chord at the panel point.

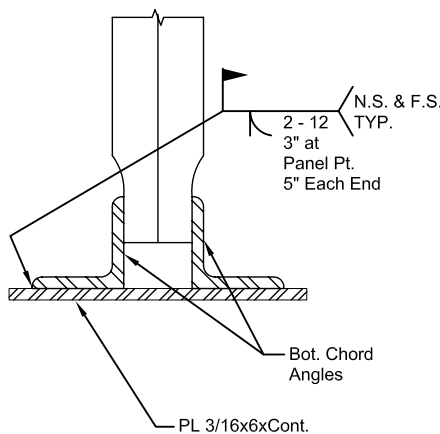

Fig. 22 Bottom chord reinforcement.

5. Check local buckling of the reinforcing:

Check local buckling of the 3/4-in.-diameter bar between welds. The clear distance between welds is 9.5 in. Use an unbraced length of 10 in. for calculation purposes.

Slenderness ratio of the bar is

$$\frac{L}{r} = \frac{10}{0.1875} = 53 \rightarrow F_a = 18.08 \text{ ksi} < 18.53 \text{ ksi}$$

and controls the design.

By observation the chord reinforcement is adequate using $F_a = 18.08$ ksi.

The reinforcing shown in Figure 21 is adequate.

Bottom Chord Reinforcing:

Total area required is

$$A_r = \frac{P_t - P_p}{P_o - P_p} A_e$$

where

- $P_t = 35.2$ kips
- $P_p = 6.2$ kips
- $P_o = 28.4$ kips
- $A_e = 1.132 \text{ in.}^2$ (area of original two $L1.75 \times 1.75 \times 0.170$)

Thus,

$$A_r = \frac{35.2 - 6.2}{28.4 - 6.2} (1.132) = 1.48 \text{ in.}^2$$

The required area of reinforcing is

$$\begin{aligned} A_r &= A_t - A_e \\ &= 1.48 - 1.132 \\ &= 0.35 \text{ in.}^2 \end{aligned}$$

For this example use a plate rather than rods for the reinforcing. The total width of the bottom chord including the gap between the angles is 5 in. Thus use a 6-in.-wide plate to accommodate down hand welding. Using a 3/16-in.-thick plate the area of the plate provided is

$$A_{r,f} = \frac{3}{16} \times 6 = 1.125 \text{ in.}^2$$

$> 0.35 \text{ in.}^2$ required. **o.k.**

The force in the reinforcing member is

$$P_r = \left(\frac{A_{rf}}{A_t} \right) (P_r - P_p) = \left(\frac{1.125}{2.257} \right) (35.2 - 6.2) = 14.46 \text{ kips}$$

Check stress in reinforcing plate:

$$F = P/A = 14.46/1.125 = 12.85 \text{ ksi}$$

A36 material is ok.

Using $\frac{1}{8}$ in. fillet welds with E70 electrodes, the allowable shear per weld equals $(0.707)(0.125 \text{ in.})(21 \text{ ksi}) = 1.86 \text{ kips/in.}$ The total length of weld required to develop the force in each rod equals $14.46/1.86 = 7.77 \text{ in.}$ The 10 in. of weld shown in Figure 21 is more than adequate. The plate is welded to the bottom chord as shown in Figure 22. Between panel points, the plate is stitch welded 2 in. at 12 in. center-to-center.

SUMMARY

Approaches for the strengthening of steel joists have been presented. Several suggested types of reinforcing members have been suggested along with recommended attachment details. The procedures and details presented do not constitute an exhaustive list of how reinforcement can be designed and detailed; however, they provide the designer with ideas and concepts to solve individual joist strengthening requirements.

REFERENCES

- AISC (1989), *Specification for Structural Steel Buildings, Allowable Stress Design and Plastic Design*, June 1, 1989, American Institute of Steel Construction, Inc., Chicago, IL.
- Nucor (2002), *Designing with Steel Joists, Joist Girders and Steel Deck*, Nucor Corporation, Charlotte, NC.
- SJI (2003), *75-Year Steel Joist Manual*, Steel Joist Institute, Myrtle Beach, SC.
- SJI (2005), *Standard Specifications for Open Web Steel Joists, K-Series*, Steel Joist Institute, Myrtle Beach, SC.

