

Fundamentals of Beam Bracing

JOSEPH A. YURA

INTRODUCTION

The purpose of this paper is to provide a fairly comprehensive view of the subject of beam stability bracing. Factors that affect bracing requirements will be discussed and design methods proposed which are illustrated by design examples. The design examples emphasize simplicity. Before going into specific topics related to beam bracing, some important concepts developed for column bracing by Winter (1960) will be presented because these concepts will be extended to beams later.

For a perfectly straight column with a discrete midheight brace stiffness β_L , the relationship between P_{cr} and β_L is shown in Figure 1 (Timoshenko and Gere, 1961). The column buckles between brace points at full or ideal bracing; in this case the ideal brace stiffness $\beta_i = 2P_e/L_b$ where $P_e = \pi^2 EI/L_b^2$. Any brace with stiffness up to the ideal value will increase the column buckling load. Winter (1960) showed that effective braces require not only adequate *stiffness* but also sufficient *strength*. The strength requirement is directly related to the magnitude of the initial out-of-straightness of the member to be braced.

The heavy solid line in Figure 2(a) shows the relationship between Δ_T , the total displacement at midheight, and P for a column with a hinge assumed at the midheight brace point (Winter's model), an initial out-of-straightness Δ_o at midheight and a midheight brace stiffness equal to the ideal value. For $P = 0$, $\Delta_T = \Delta_o$. When P increases and approaches the buckling load, $\pi^2 EI/L_b^2$, the total deflection Δ_T becomes very large. For example, when the applied load is within five percent of the buckling load, $\Delta_T = 20\Delta_o$. If a brace stiffness twice the value of the ideal stiffness is used, much smaller deflections occur. When the load just reaches the buckling load, $\Delta_T = 2\Delta_o$. For $\beta_L = 3\beta_i$ and $P = P_e$, $\Delta_T = 1.5\Delta_o$. The brace force, F_{br} , is equal to $(\Delta_T - \Delta_o)\beta_L$ and is directly related to the magnitude of the initial imperfection. If a member is fairly straight, the brace force will be small. Conversely, members with large initial out-of-straightness will require larger braces. If the brace stiffness is equal to the ideal value, then the brace force gets very large as the buckling load is approached because Δ_T gets very large as shown in Figure 2(a). For example, at $P = 0.95P_{cr}$ and $\Delta_o = L_b/500$, the brace force is 7.6 percent of P_e which is off the scale of the graph. Theoretically the brace force will be

infinity when the buckling load is reached if the ideal brace stiffness is used. Thus, a brace system will not be satisfactory if the theoretical ideal stiffness is provided because the brace forces get too large. If the brace stiffness is overdesigned, as represented by $\beta_L = 2\beta_i$ and $3\beta_i$ curves in Figure 2(b), then the brace forces will be more reasonable. For a brace stiffness twice the ideal value and a $\Delta_o = L_b/500$, the brace force is only 0.8% P_e at $P = P_e$, not infinity as in the ideal brace stiffness case. For a brace stiffness ten times the ideal value, the brace force will reduce even further to 0.44 percent. At P_{cr} , the brace force cannot be less than 0.4% P corresponding to $\Delta_T = \Delta_o$ (an infinitely stiff brace) for $\Delta_o = L_b/500$. For design $F_{br} = 1\%P$ is recommended based on a brace stiffness of twice the ideal value and an initial out-of-straightness of $L_b/500$ because the Winter model gives slightly unconservative results for the midspan brace problem (Plaut, 1993).

Published bracing requirements for beams usually only consider the effect of brace stiffness because perfectly straight beams are considered. Such solutions should not be used directly in design. Similarly, design rules based on strength considerations only, such as a 2 percent rule, can result in inadequate bracing systems. Both strength and stiffness of the brace system must be checked.

BEAM BRACING SYSTEMS

Beam bracing is a much more complicated topic than column bracing. This is due mainly to the fact that most column buckling involves primarily bending whereas beam buckling involves both flexure and torsion. An effective beam brace resists twist of the cross section. In general,

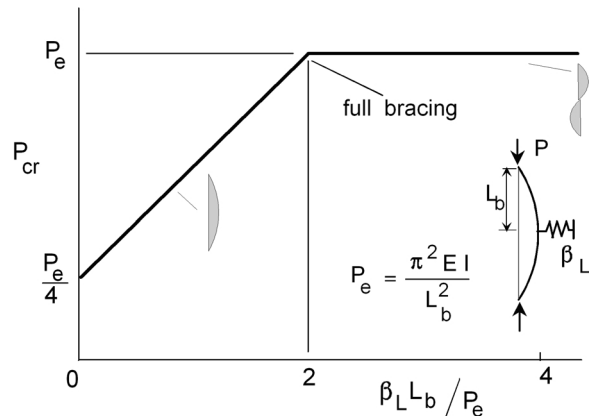

Fig. 1. Effect of brace stiffness.

Joseph A. Yura is Cockrell Family Regents Chair in civil engineering, University of Texas at Austin.

bracing may be divided into two main categories; lateral and torsional bracing as illustrated in Figure 3. Lateral bracing restrains lateral displacement as its name implies. The effectiveness of a lateral brace is related to the degree that twist of the cross section is restrained. For a simply supported I-beam subjected to uniform moment, the center of twist is located at a point outside the tension flange; the top flange moves laterally much more than the bottom flange. Therefore, a lateral brace restricts twist best when it is located at the top flange. Lateral bracing attached at the bottom flange of a simply supported beam is almost totally ineffective. A torsional brace can be differentiated from a lateral brace in that twist of the cross section is restrained directly, as in the case of twin beams with a cross frame or diaphragm between the members. The cross frame location, while able to displace laterally, is still considered a brace point because twist is prevented. Some systems such as concrete slabs can act both as lateral and torsional braces. Bracing that controls both lateral movement and twist is more effective than lateral or torsional braces acting alone (Tong and Chen, 1988; Yura and Phillips, 1992). However, since bracing requirements are so minimal, it is more practical to develop separate design recommendations for these two types of systems.

Lateral bracing can be divided into four categories: relative, discrete (nodal), continuous and lean-on. A relative brace system controls the relative lateral movement between two points along the span of the girder. The top flange horizontal truss system shown in Figure 4 is an example of a relative brace system. The system relies on the fact that if the individual girders buckle laterally, points **a** and **b** would move different amounts. Since the diagonal brace prevents points **a** and **b** from moving different amounts, lateral buckling cannot occur except between the brace points. Typically, if a perpendicular cut anywhere

along the span length passes through one of the bracing members, the brace system is a relative type. Discrete systems can be represented by individual lateral springs along the span length. Temporary guy cables attached to the top flange of a girder during erection would be a discrete bracing system. A lean-on system relies on the lateral buckling strength of lightly loaded adjacent girders to laterally support a more heavily loaded girder when all the girders are horizontally tied together. In a lean-on system all girders must buckle simultaneously. In continuous bracing systems, there is no "unbraced" length. In this paper only relative and discrete systems that provide full bracing will be considered. Design recommendations for lean-on systems and continuous lateral bracing are given elsewhere (Yura, Phillips, Raju, and Webb, 1992). Torsional brace systems can be discrete or continuous (decking) as shown in Figure 3. Both types are considered herein.

Some of the factors that affect brace design are shown in Figure 5. A lateral brace should be attached where it best offsets the twist. For a cantilever beam in (a), the best location is the top tension flange, not the compression flange. Top flange loading reduces the effectiveness of a top flange brace because such loading causes the center of twist to shift toward the top flange as shown in (b), from its position below the flange when the load is at the midheight of the beam. Larger lateral braces are required for top flange loading. If cross members provide bracing above the top flange, case (c), the compression flange can still deflect laterally if stiffeners do not prevent cross-section distortion. In the following sections the effect of loading conditions, load location, brace location and cross-section distortion on brace requirements will be presented. All the cases considered were solved using an elastic finite element program identified as BASP in the figures (Akay, Johnson, and Will, 1977; Choo, 1987). The solutions and the design recommenda-

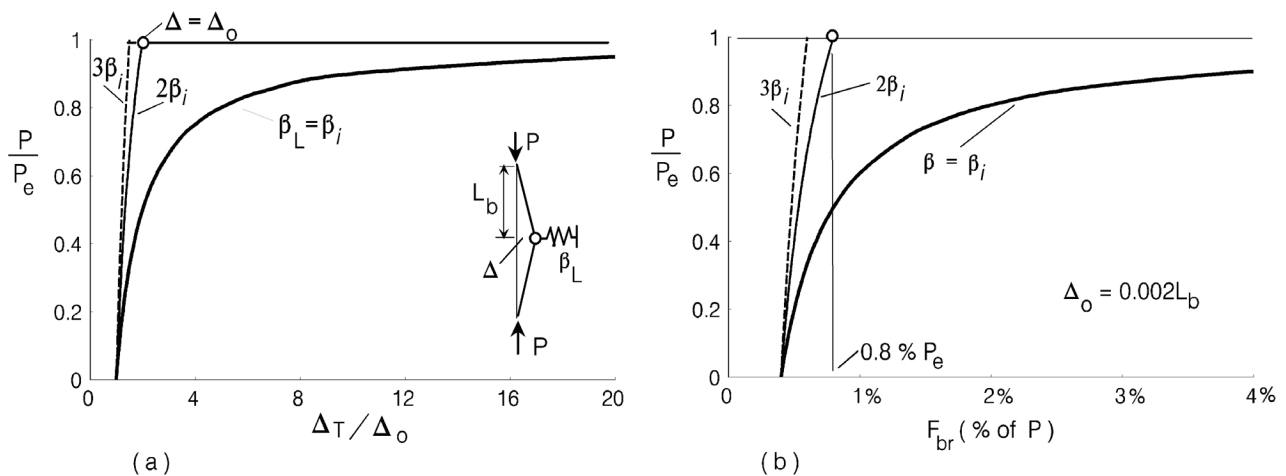
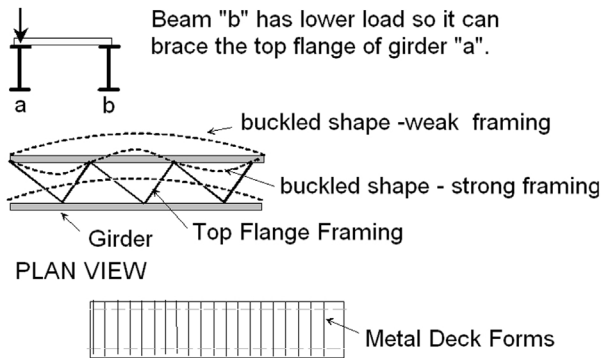

Fig. 2. Braced Winter column with initial out-of-straightness.

tions presented are consistent with the work of others: Kirby and Nethercot (1979), Lindner and Schmidt (1982), Medland (1980), Milner (1977), Nakamura (1988), Nakamura and Wakabayashi (1981), Nethercot (1989), Taylor

and Ojalvo (1966), Tong and Chen (1988), Trahair and Nethercot (1982), Wakabayashi and Nakamura (1983), and Wang and Nethercot (1989).

LATERAL BRACING



TORSIONAL BRACING

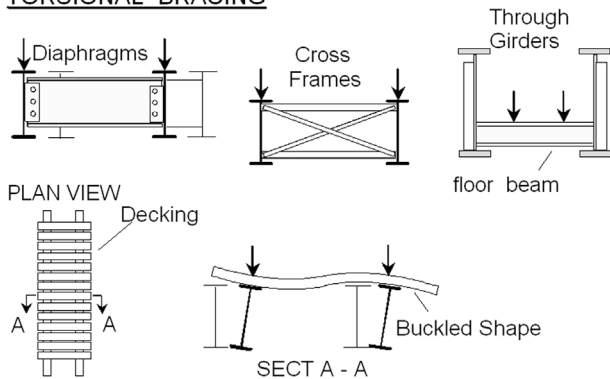

Fig. 3. Types of beam bracing.

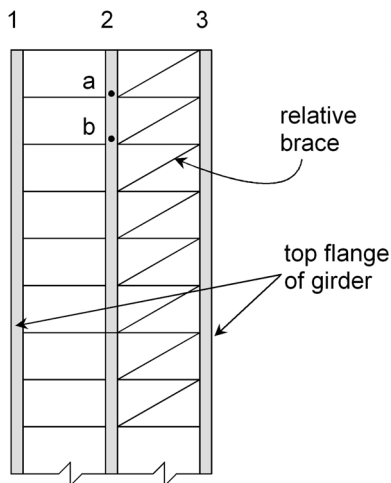

Fig. 4. Relative bracing.

LATERAL BRACING OF BEAMS

Behavior

The uniform moment condition is the basic case for lateral buckling of beams. If a lateral brace is placed at the midspan of such a beam, the effect of different brace sizes (stiffness) is illustrated by the finite element solutions for a W16x26 section 20-ft long in Figure 6. For a brace attached to the top (compression) flange, the beam buckling capacity initially increases almost linearly as the brace stiffness increases. If the brace stiffness is less than 1.6 k/in., the beam buckles in a shape resembling a half sine curve. Even though there is lateral movement at the brace point, the load increase can be more than three times the unbraced case. The ideal brace stiffness required to force the beam to buckle between lateral supports is 1.6 k/in. in

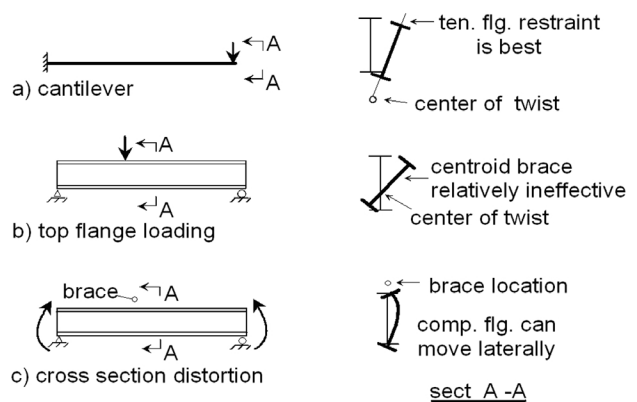

Fig. 5. Factors that affect brace stiffness.

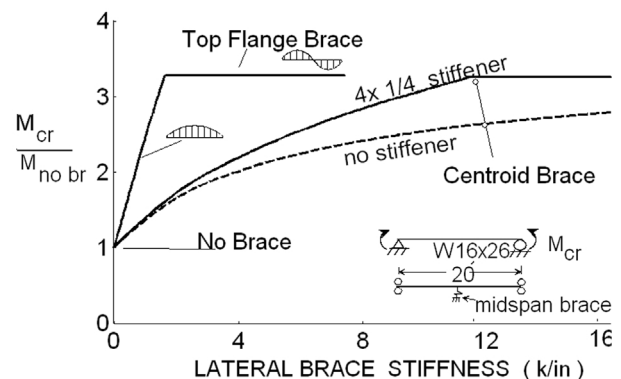

Fig. 6. Effect of lateral brace location.

this example. Any brace stiffness greater than this value does not increase the beam buckling capacity and the buckled shape is a full sine curve. When the brace is attached at the top flange, there is no cross section distortion. No stiffener is required at the brace point.

A lateral brace placed at the centroid of the cross section requires an ideal stiffness of 11.4 kips/in. if a $4 \times \frac{1}{4}$ stiffener is attached at midspan and 53.7 kips/in. (off scale) if no stiffener is used. Substantially more bracing is required for the no stiffener case because of web distortion at the brace point. The centroidal bracing system is less efficient than the top flange brace because the centroidal brace force causes the center of twist to move *above* the bottom flange and closer to the brace point, which is undesirable for lateral bracing.

For the case of a beam with a concentrated centroid load at midspan, shown in Figure 7, the moment varies along the length. The ideal centroid brace (110 kips/in.) is 44 times larger than the ideal top flange brace (2.5 kips/in.). For both brace locations, cross-section distortion had a minor effect on P_{cr} (less than 3 percent). The maximum beam moment at midspan when the beam buckles between the braces is 1.80 times greater than the uniform moment case which is close to the C_b factor of 1.75 given in specifications (AISC, AASHTO). This higher buckling moment is the main reason why the ideal top flange brace requirement is 1.56 times greater (2.49 versus 1.6 kips/in.) than the uniform moment case.

Figure 8 shows the effects of load and brace position on the buckling strength of laterally braced beams. If the load is at the top flange, the effectiveness of a top flange brace is greatly reduced. For example, for a brace stiffness of 2.5 kips/in., the beam would buckle between the ends and the midspan brace at a centroid load close to 50 kips. If the load is at the top flange, the beam will buckle at a load of 28 kips. For top flange loading, the ideal top flange brace would have to be increased to 6.2 kips/in. to force buckling

between the braces. The load position effect must be considered in the brace design requirements. This effect is even more important if the lateral brace is attached at the centroid. The results shown in Figure 8 indicate that a centroid brace is almost totally ineffective for top flange loading. This is not due to cross section distortion since a stiffener was used at the brace point. The top flange loading causes the center of twist at buckling to shift to a position close to mid-depth for most practical unbraced lengths, as shown in Figure 5. Since there is virtually no lateral displacement near the centroid for top flange loading, a lateral brace at the centroid will not brace the beam. Because of cross-section distortion and top flange loading effects, lateral braces at the centroid are not recommended. Lateral braces must be placed near the top flange of simply supported and overhanging spans. Design recommendations will be developed only for the top flange lateral bracing situation. Torsional bracing near the centroid or even the bottom flange can be effective as discussed later.

The load position effect discussed above assumes that the load remains vertical during buckling and passes through the plane of the web. In the laboratory, a top flange loading condition is achieved by loading through a knife-edge at the middle of the flange. In actual structures the load is applied to the beams through secondary members or the slab itself. Loading through the deck can provide a beneficial "restoring" effect illustrated in Figure 9. As the beam tries to buckle, the contact point shifts from mid-flange to the flange tip resulting in a restoring torque that increases the buckling capacity. Unfortunately, cross-section distortion severely limits the benefits of tipping. Lindner and Schmidt (1982) developed a solution for the tipping effect, which considers the flange-web distortion. Test data (Lindner and Schmidt, 1982; Raju, Webb, and Yura, 1992) indicate that a cross member merely resting (not positively attached) on the top flange can significantly increase the lateral buckling capacity. The restoring solution is sensitive to the initial

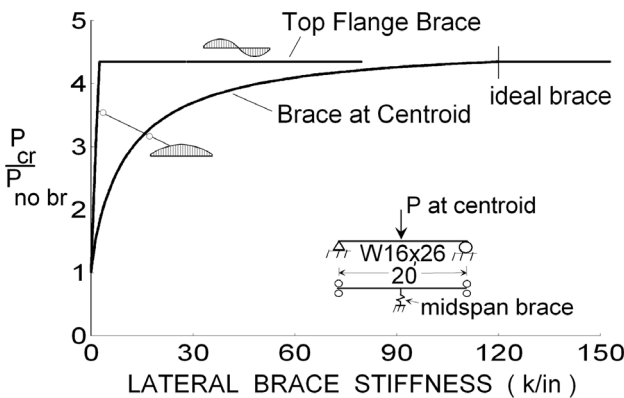

Fig. 7. Midspan load at centroid.

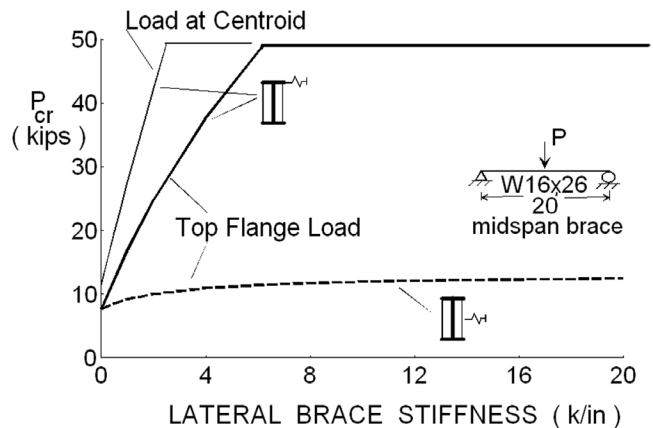

Fig. 8. Effect of brace and load position.

shape of the cross section and location of the load point on the flange. Because of these difficulties, it is recommended that the restoring effect not be considered in design.

When a beam is bent in double curvature, the compression flange switches from the top flange to the bottom flange at the inflection point. Beams with compression in both the top and bottom flanges along the span have more severe bracing requirements than beams with compression on just one side as illustrated by the comparison of the cases given in Figure 10. The solid lines are finite element solutions for a 20-ft long W16x26 beam subjected to equal but opposite end moments and with lateral bracing at the midspan inflection point. For no bracing the buckling moment is 1,350 kip-in. A brace attached to one flange is ineffective for reverse curvature because twist at midspan is not prevented. If lateral bracing is attached to both flanges, the buckling moment increases nonlinearly as the brace stiffness increases to 24 kips/in., the ideal value shown by the black dot. Greater brace stiffness has no effect because buckling occurs between the brace points. The ideal brace stiffness for a beam with a concentrated midspan load is 2.6 kips/in. at $M_{cr} = 2,920$ kip-in. as shown by the dashed lines.

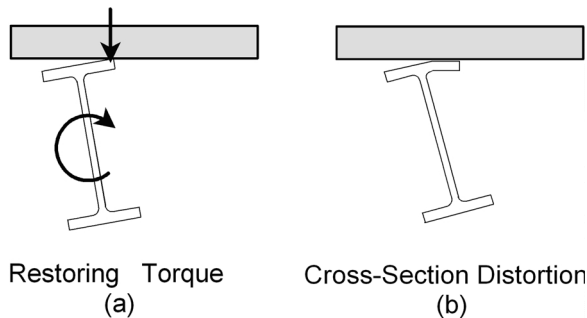

Fig. 9. Tipping effect.

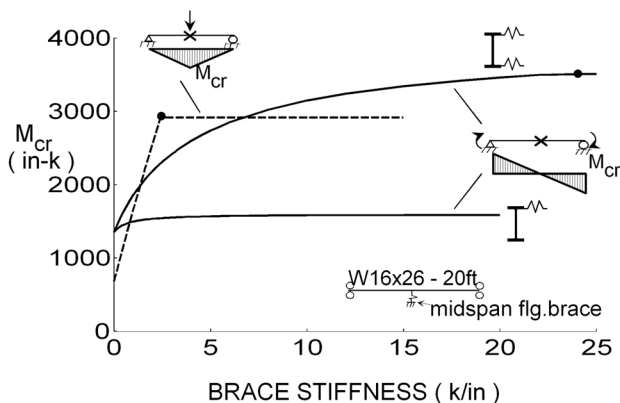

Fig. 10. Beams with inflection points.

For the two load cases the moment diagrams between brace points are similar, maximum moment at one end and zero moment at the other end. In design, a C_b value of 1.75 is used for these cases which corresponds to an expected maximum moment of 2,810 kip-in. The double curvature case reached a maximum moment 25 percent higher because of warping restraint provided at midspan by the adjacent tension flange. In the concentrated load case, no such restraint is available since the compression flanges of both unbraced segments are adjacent to each other. On the other hand, the brace stiffness at each flange must be 9.2 times the ideal value of the concentrated load case to achieve the 25 percent increase. Since warping restraint is usually ignored in design $M_{cr} = 2,810$ kip-in. is the maximum design moment. At this moment level, the double curvature case requires a brace stiffness of 5.6 kips/in. which is about twice that required for the concentrated load case. The results in Figure 10 show that not only is it incorrect to assume that an inflection point is a brace point but also that bracing requirements for beams with inflection points are greater than cases of single curvature. For other cases of double curvature, such as uniformly loaded beams with end restraint (moments), the observations are similar.

Up to this point, only beams with a single midspan lateral brace have been discussed. The bracing effect of a beam with multiple braces is shown in Figure 11. The response of a beam with three equally spaced braces is shown by the solid line. When the lateral brace stiffness, β_L , is less than 0.14 kips/in., the beam will buckle in a single wave. In this region a small increase in brace stiffness greatly increases the buckling load. For $0.14 < \beta_L < 1.14$, the buckled shape switches to two waves and the relative effectiveness of the lateral brace is reduced. For $1.4 < \beta_L < 2.75$, the buckled shape is three waves. The ideal brace stiffness is 2.75 kips/in. at which the unbraced length can be considered 10 ft. For the 20-ft span with a single brace at midspan discussed previously which is shown by the dashed line, a

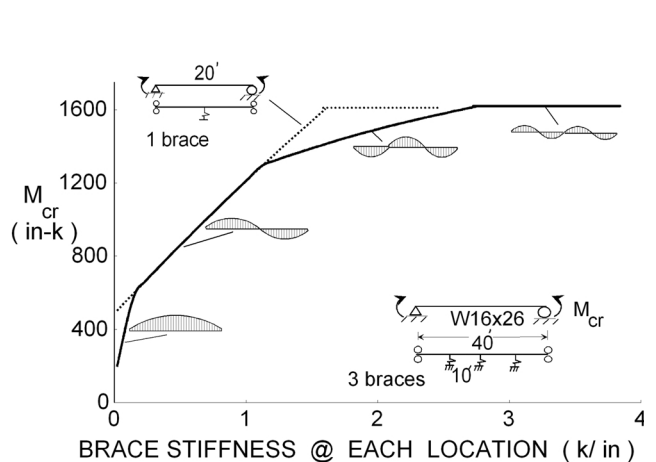

Fig. 11. Multiple lateral bracing.

brace stiffness of only 1.6 kips/in. was required to reduce the unbraced length to 10 ft. Thus the number of lateral braces along the span affects the brace requirements. Similar behavior has been derived for columns (Timoshenko and Gere, 1961) where changing from one brace to three braces required an increase in ideal column brace stiffness of 1.71, which is the same as that shown in Figure 11 for beams, $2.75/1.6 = 1.72$.

Yura and Phillips (1992) report the results of a test program on the lateral and torsional bracing of beams for comparison with the theoretical studies presented above. Some typical test results show good correlation with the finite element solutions in Figure 12. Since the theoretical results were reliable, significant variables from the theory were included in the development of the design recommendations given in the following section. In summary, moment gradient, brace location, load location, brace stiffness and number of braces affect the buckling strength of laterally braced beams. The effect of cross-section distortion can be effectively eliminated by placing the lateral brace near the top flange.

Lateral Brace Design

In the previous section it was shown that the buckling load increases as the brace stiffness increases until full bracing causes the beam to buckle between braces. In many instances the relationship between bracing stiffness and buckling load is nonlinear as evidenced by the response shown in Figure 11 for multiple braces. A general design equation has been developed for braced beams, which gives good correlation with exact solutions for the entire range of zero bracing to full bracing (Yura et al., 1992). That braced beam equation is applicable to both continuous and discrete bracing systems, but it is fairly complicated. In most design situations full bracing is assumed or desired, that is, buckling between the brace points is assumed. For full bracing,

a simpler design alternative based on Winter's approach was developed (Yura et al., 1992) and is presented below.

For elastic beams under uniform moment, the Winter ideal lateral brace stiffness required to force buckling between the braces is

$$\beta_i = N_i P_f / L_b$$

where

$$P_f = \pi^2 E I_{yc} / L_b^2$$

I_{yc} = out-of-plane moment of inertia of the compression flange which is $I_y/2$ for doubly symmetric cross sections

N_i = coefficient depending on the number of braces n within the span, as given in Table 1 (Winter, 1960) or approximated by $N_i = 4 - (2/n)$.

The C_b factor given in design specifications for nonuniform moment diagrams can be used to estimate the increased brace requirements for other loading cases. For example, for a simply supported beam with a load and brace at midspan shown in Figure 7, the full bracing stiffness required is 1.56 times greater than the uniform moment case. The value of C_b equal to 1.75 for this loading case provides a conservative estimate of the increase. An additional modifying factor $C_d = 1 + (M_S/M_L)^2$ is required when there are inflection points along the span (double curvature), where M_S and M_L are the maximum moments causing compression in the top and bottom flanges as shown in Figure 13. The moment ratio must be equal to or less than one, so C_d varies between 1 and 2. In double curvature cases lateral braces must be attached to both flanges. Top flange loading increases the brace requirements even when bracing is provided at the load point. The magnitude of the increase is affected by the number of braces along the span as given by the modifying factor $C_L = 1 + (1.2/n)$. For one brace $C_L = 2.2$, however, for many braces top flange loading has no effect on brace requirements, i.e., $C_L = 1.0$.

In summary, a modified Winter's ideal bracing stiffness can be defined as follows:

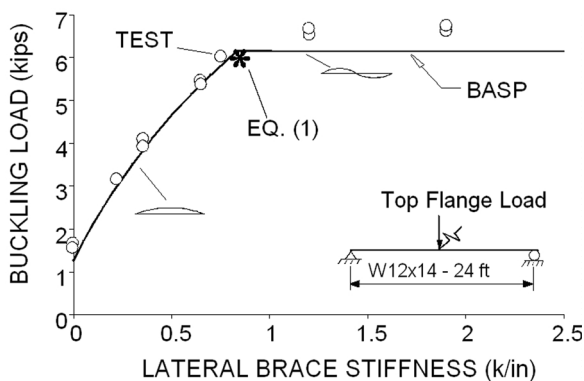

Fig. 12. Lateral bracing tests.

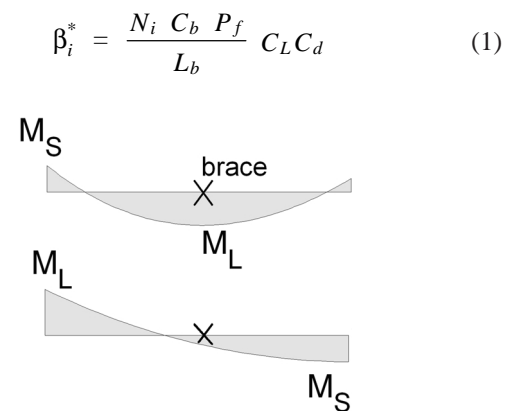

Fig. 13. Double curvature.

Number of Braces	Brace Coefficient
1	2
2	3
3	3.41
4	3.63
Many	4.0

Chart 1. Lateral Bracing Design Requirements

Stiffness:

$$\beta_L^* = 2N_i(C_bP_f)C_L C_d/L_b \text{ or } 2N_i(M_f/h)C_L C_D/L_b \quad (2)$$

where

$N_i = 4 - (2/n)$ or the coefficient in Table 1 for discrete bracing; = 1.0 for relative bracing

$C_bP_f = C_b\pi^2EI_{yc}/L_b^2$; or = (M_f/h) where M_f is the maximum beam moment

$C_L = 1 + (1.2/n)$ for top flange loading; = 1.0 for other loading

$C_d = 1 + (M_s/M_L)^2$ for double curvature; = 1.0 for single curvature

$n =$ number of braces

Strength:

Discrete bracing: $F_{br} = 0.01C_L C_d M_f/h \quad (3)$

Relative bracing: $F_{br} = 0.004C_L C_d M_f/h \quad (4)$

For the W12x14 beams laterally braced at midspan shown in Figure 12, $L_b = 144$ in., $N_i = 2$, $C_b = 1.75$, $C_L = 1 + 1.2/1 = 2.2$, and $P_f = \pi^2 (29,000) (2.32/2)/(144)^2 = 16.01$ kips. Therefore, the lateral brace stiffness, β_i^* is 0.856 kips/in. which is shown by the * in Figure 12. Equation 1 compares very favorably with the test results and with the finite element results. For design, the ideal stiffness given by Equation 1 must be doubled for beams with initial out-of-straightness so brace forces can be maintained at reasonable levels as discussed earlier. The brace force requirement for beams follows directly from the column $F_{br} = 0.01P$ for discrete braces given earlier. The column load P is replaced by the equivalent compressive beam flange force, either (C_bP_f) or M_f/h , where M_f is the maximum beam moment and h is the distance between flange centroids. The M_f/h estimate of the flange force is applicable for both the elastic and inelastic regions. For relative bracing the force requirement for beams is $0.004P$ (adjusted by C_L and C_d), which follows directly from the relative

brace requirements for columns (Yura, 1995). The lateral brace design recommendations, given in Chart 1, are based on an initial out-of-straightness of adjacent brace points of $L_b/500$. For discrete braces the combined values of N_i and C_L vary between 4.0 and 4.8 for all values of n , so Equation 2 can be simplified for all situations to $\beta_L^* = 10M_f/hL_b$ for single curvature and $\beta_L^* = 20M_f/hL_b$ for double curvature. For relative bracing Equation 2 becomes $4M_f/hL_b$ for single curvature and $C_L = 2.0$.

Some adjustments to the design requirements are necessary to account for the different design code methodologies, i.e. allowable stress design, load factor design, etc. In AASHTO-LFD and AISC-LRFD, M_f is the factored moment and in Allowable Stress Design, M_f is based on service loads. The C_bP_f form of Equation 2 can be used directly for all specifications because it is based on geometric properties of the beam, i.e. $\beta_L \geq \beta_L^*$ where β_L is the brace stiffness provided. The brace strength requirements, Equations 3 and 4, can also be used directly since the design strengths or resistances given in each code are consistent with the appropriate factored or service loads. Only the M_f/h form of Equation 2, which relies on the applied load level used in the structural analysis must be altered as follows:

AISC-LRFD: $\beta_L \geq \beta_L^*/\phi$ where $\phi = 0.75$ is recommended

AISC-ASD: $\beta_L \geq 2\beta_L^*$ where 2 is a safety factor = (load factor = 1.5)/ ϕ

AASHTO-LFD: $\beta_L \geq \beta_L^*$ no change

The discrete and relative lateral bracing requirements are illustrated in the following two design examples.

Lateral Brace Design Examples

Two different lateral bracing systems are used to stabilize five composite steel plate girders during bridge construction: a discrete bracing system in Example 1 and relative bracing in Example 2. The AASHTO-Load Factor Design Specification is used. Each brace shown dashed in Example 1 controls the lateral movement of one point along the span, whereas the diagonals in the top flange truss system shown in Example 2 control the relative lateral displacement of two adjacent points. Relative systems require less than $1/2$ the brace force and from $1/2$ to $1/4$ of the stiffness for discrete systems. In both examples, a tension type structural system was used but the bracing formulas are also applicable to compression systems such as K-braces. In Example 1 the full bracing requirements for strength and stiffness given by Equations 2 and 3 are based on each brace stabilizing five girders. Since the moment diagram gives compression in one flange, C_d for double curvature is not considered, i.e. $C_d = 1.0$.

In both examples, stiffness controls the brace area, not the strength requirement. In Example 1 the stiffness crite-

tion required a brace area 3.7 times greater than the strength formula. Even if the brace was designed for 2 percent of the compression flange force (a commonly used bracing rule), the brace system would be inadequate. It is important to recognize that *both* stiffness and strength must be adequate for a satisfactory bracing system.

TORSIONAL BRACING OF BEAMS

Examples of torsional bracing systems were shown in Figure 3. Twist can be prevented by attaching a deck to the top flange of a simply supported beam, by floor beams attached near the bottom tension flange of through girders or by diaphragms located near the centroid of the stringer. Twist can also be restrained by cross frames that prevent the relative movement of the top and bottom flanges. The effectiveness of torsional braces attached at different locations on the cross section will be presented.

Behavior

The finite element solution for a simply supported beam with a top flange torsional brace attached at midspan is shown in Figure 14. The buckling strength-brace stiffness relationships are non-linear and quite different from the top flange lateral bracing linear response given in Figure 6 for the same beam and loading. For top flange lateral bracing a stiffener has no effect. A torsional brace can only increase the buckling capacity about fifty percent above the unbraced case if no stiffener is used. Local cross-section distortion at midspan reduces the brace effectiveness. If a web stiffener is used with the torsional brace attached to the compression flange, then the buckling strength will increase until buckling occurs between the braces at 3.3 times the unbraced capacity. The ideal or full bracing requires a stiffness of 1,580 in.-k/radian for a $4 \times \frac{1}{4}$ stiffener and 3,700 in.-k/radian for a $2.67 \times \frac{1}{4}$ stiffener. Tong and Chen (1988) developed a closed form solution for ideal torsional brace stiffness neglecting cross-section distortion that is given by

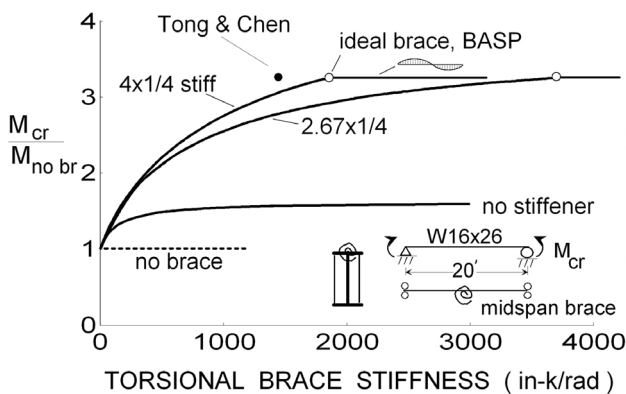

Fig. 14. Torsional brace at midspan.

the solid dot at 1,450 in.-k/radian in Figure 14. The difference between the Tong and Chen solution and the BASP results is due to web distortion. Their solution would require a $6 \times \frac{3}{8}$ stiffener to reach the maximum buckling load. If the Tong and Chen ideal stiffness (1,450 in.-k/radian) is used with a $2.67 \times \frac{1}{4}$ stiffener, the buckling load is reduced by 14 percent; no stiffener gives a 51 percent reduction.

Figure 15 shows that torsional bracing on the tension flange (dashed line) is just as effective as compression flange bracing (solid line), even with no stiffener. If the beam has no stiffeners, splitting bracing equally between the two flanges gives a greater capacity than placing all the bracing on just one flange. The dot-dash curve is the solution if transverse stiffeners prevent web distortion. The distortion does not have to be gross to affect strength, as shown in Figure 16 for a total torsional brace stiffness of 3,000 in.-k/radian. If the W16x26 section has transverse stiffeners, the buckled cross section at midspan has no distortion as shown by the heavy solid lines and $M_{cr} = 1,582$ kip-in. If no stiffeners are used, the buckling load drops to 1,133 kip-in., a 28 percent decrease, yet there is only slight distortion as shown by the dashed shape. The overall angle of twist

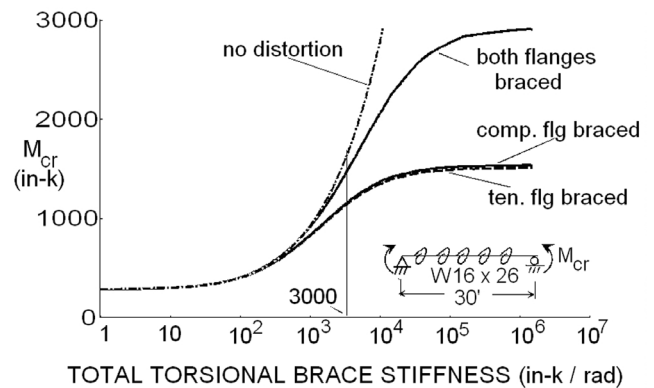

Fig. 15. Effect of torsional brace location.

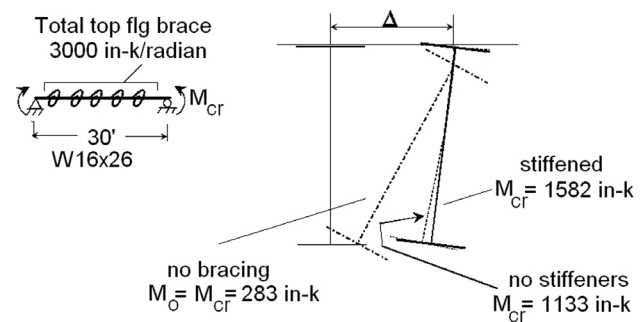

Fig. 16. Effect of cross-section distortion.

for the braced beam is much smaller than the twist in the unbraced case (dot-dash curve).

The effect of load position on torsionally braced beams is not very significant, as shown in Figure 17. The difference in load between the curves for top flange and centroid loading for braced beams is almost equal to the difference in strength for the unbraced beams (zero brace stiffness). The ideal brace stiffness for top flange loading is only 18 percent greater than for centroidal loading. For lateral bracing (see Figure 8), the ideal brace stiffness for top flange loading is 2.5 times that for centroidal loading.

Figure 18 summarizes the behavior of a 40-ft span with three equal torsional braces spaced 10-ft apart. The beam was stiffened at each brace point to control the distortion. The response is non-linear and follows the pattern discussed earlier for a single brace. For brace stiffness less than 1,400 in.-k/radian, the stringer buckled into a single wave. Only in the stiffness range of 1,400-1,600 in.-k/radian did multi-wave buckled shapes appear. The ideal brace stiffness at each location was slightly greater than 1,600 in.-k/radian. This behavior is very different than the multiple lateral bracing case for the same beam shown in Figure 11. For multiple lateral bracing the beam buckled

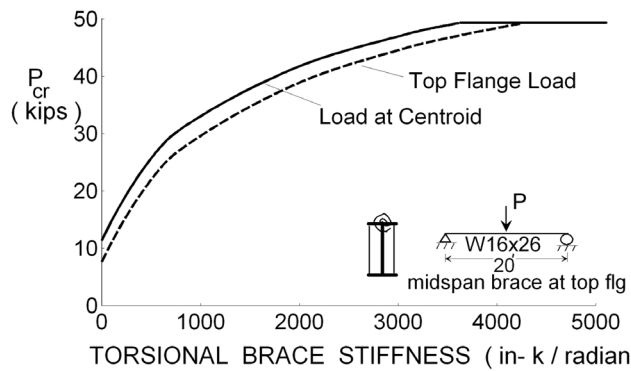

Fig. 17. Effect of load position.

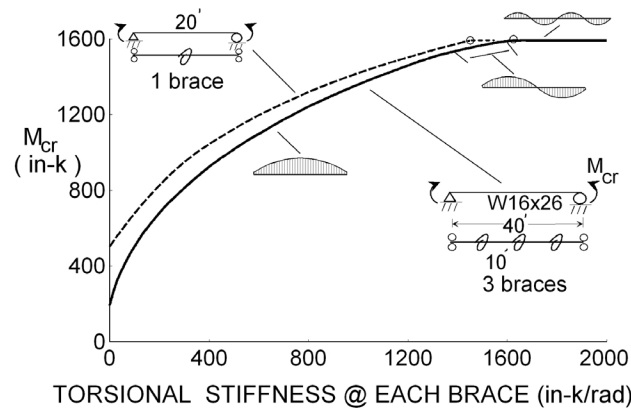

Fig. 18. Multiple torsional braces.

into two waves when the moment reached 600 kip-in. and then into three waves at $M_{cr} = 1,280$ kip-in. For torsional bracing, the single wave controlled up to $M_{cr} = 1,520$ kip-in. Since the maximum moment of 1,600 kip-in. corresponds to buckling between the braces, it can be assumed, for design purposes, that torsionally braced beams buckle in a single wave until the brace stiffness is sufficient to force buckling between the braces. The figure also shows that a single torsional brace at midspan of a 20-ft span (unbraced length = 10 ft) requires about the same ideal brace stiffness as three braces spaced at 10 ft. In the lateral brace case the three brace system requires 1.7 times the ideal stiffness of the single brace system, as shown in Figure 11.

Tests have been conducted on torsionally braced beams with various stiffener details which are presented elsewhere (Yura and Phillips, 1992). The tests show good agreement with the finite element solutions.

Buckling Strength of Torsionally Braced Beams

Taylor and Ojalvo (1966) give the following exact equation for the critical moment of a doubly symmetric beam under uniform moment with continuous torsional bracing

$$M_{cr} = \sqrt{M_o^2 + \bar{\beta}_b EI_y} \quad (5)$$

where

M_o = buckling capacity of the unbraced beam, kip-in.

$\bar{\beta}_b$ = attached torsional brace stiffness (in.-k/rad per in. length)

Equation 5, which assumes no cross section distortion, is shown by the dot-dash line in Figure 19. The solid lines are finite element results for a W16x26 section with no stiffeners and spans of 10 ft, 20 ft, and 30 ft under uniform moment with braces attached to the compression flange. Cross-section distortion causes the poor correlation between Equation 5 and the BASP results. Milner (1977) showed that cross-section distortion could be handled by

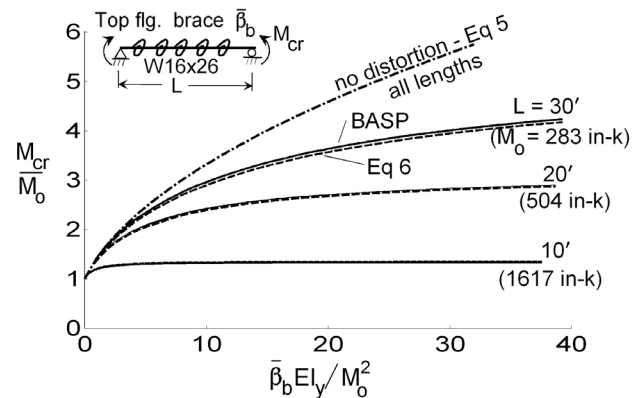

Fig. 19. Approximate buckling formula.

using an effective brace stiffness, β_T , which has been expanded (Yura et al., 1992) to include the effect of stiffeners and other factors as follows:

$$\frac{1}{\beta_T} = \frac{1}{\beta_b} + \frac{1}{\beta_{sec}} + \frac{1}{\beta_g} \quad (6)$$

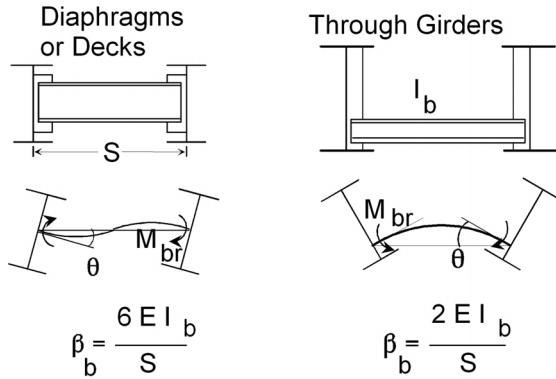

Fig. 20. Torsional bracing stiffness.

where β_b is the stiffness of the attached brace, β_{sec} is the cross-section web stiffness and β_g is the girder system stiffness. The effective brace stiffness is less than the smallest of β_b , β_{sec} or β_g .

The torsional brace stiffness, β_b , of some common torsional systems is given in Figures 20 and 21. The choice between the two cases shown in Figure 20 is based on the deck details. If the distance between the flanges of adjacent girders is maintained constant by a floor slab or decking, then all the girders must sway in the same direction and the diaphragm stiffness is $6EI_b/S$. On the other hand, if adjacent compression flanges can separate as shown for the through girders, then the diaphragm stiffness will be $2EI_b/S$. The torsional bracing stiffnesses shown in Figure 20 assume that the connection between the girder and the brace can support a bracing moment M_{br} . If partially restrained connections are used, their flexibility should also be included in Equation 6. Elastic truss analyses were used to derive the stiffness of the cross frame systems shown in Figure 21. If the diagonals of an X-system

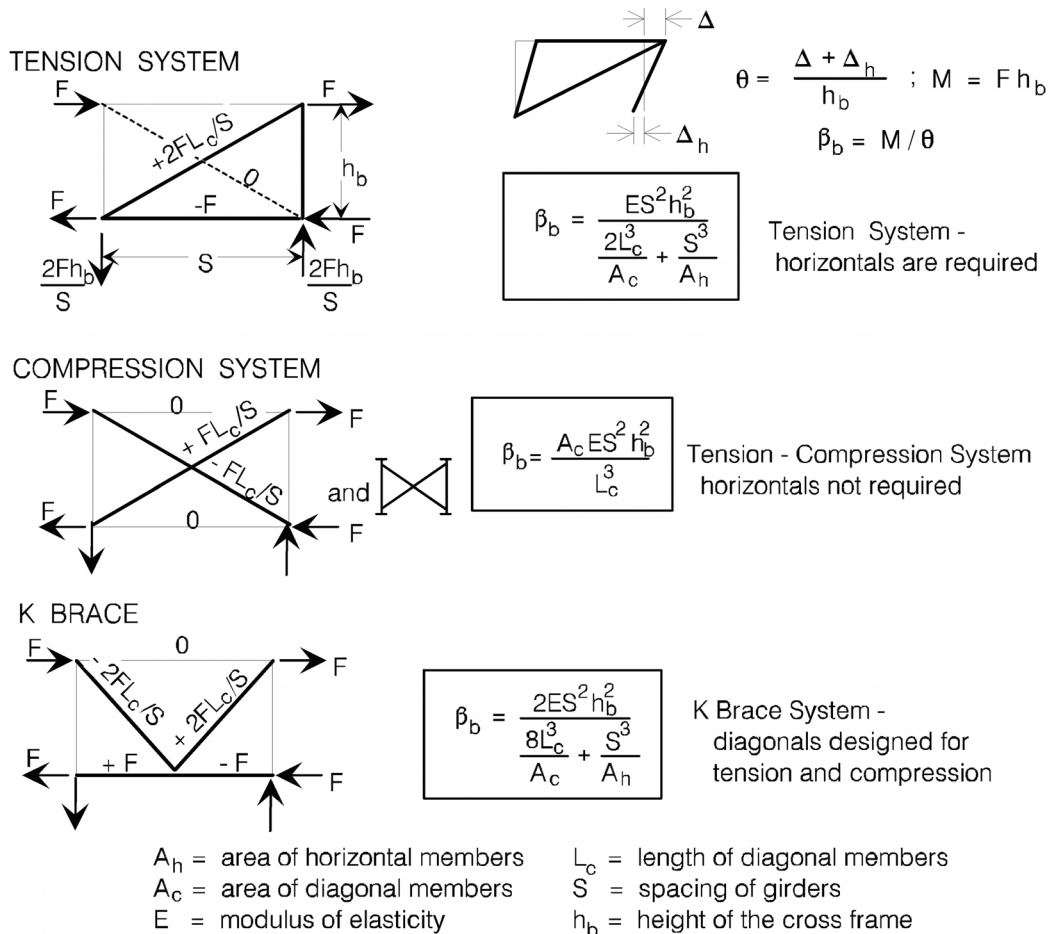

Fig. 21. Stiffness formulas for twin girder cross frames.

are designed for tension only, then horizontal members are required in the system. In the K-brace system a top horizontal is not required.

In cross frames and diaphragms the brace moments M_{br} are reacted by vertical forces on the main girders as shown in Figure 22. These forces increase some main girder moments and decrease others. The effect is greater for the twin girder system **B** compared to the interconnected system **A**. The vertical couple causes a differential displacement in adjacent girders which reduces the torsional stiffness of the cross frame system. For a brace only at midspan in a twin girder system the contribution of the in-plane girder flexibility to the brace system stiffness is

$$\beta_g = \frac{12 S^2 EI_x}{L^3} \quad (7)$$

where

I_x = strong axis moment of inertia of one girder, in.⁴

L = the span length, in.

As the number of girders increase, the effect of girder stiffness will be less significant. In multi-girder systems, the factor 12 in Equation 7 can be conservatively changed to $24(n_g - 1)^2/n_g$ where n_g is the number of girders. For example, in a six-girder system the factor becomes 100 or more than eight times the twin girder value of 12. Helwig, Yura, and Frank (1993) have shown that for twin girders the strong axis stiffness factor β_g is significant and Equation 7 can be used even when there is more than one brace along the span.

Cross-section distortion can be approximated by considering the flexibility of the web, including full depth stiffeners if any, as follows:

$$\beta_{sec} = 3.3 \frac{E}{h} \left(\frac{(N + 1.5h) t_w^3}{12} + \frac{t_s b_s^3}{12} \right) \quad (8)$$

where

t_w = thickness of web, in.

h = distance between flange centroids, in.

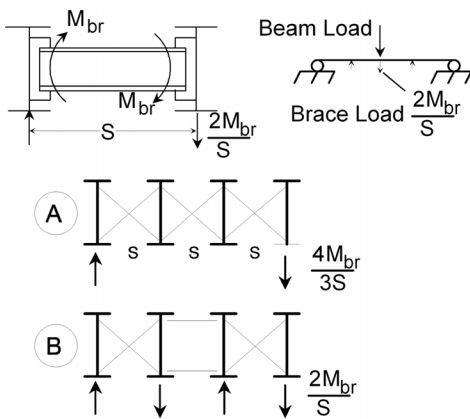

Fig. 22. Beam load from braces.

t_s = thickness of stiffener, in.

b_s = width of stiffener, in.

N = contact length of the torsional brace as shown in Figure 23, in.

For continuous bracing use an effective unit width (1 in.) instead of $(N + 1.5h)$ in Equation 8 and $\bar{\beta}_b$ in place of β_b in Equation 6 to get $\bar{\beta}_T$. The dashed lines in Figure 19 based on Equations 5 and 6 show good agreement with the finite element solutions. For the 10-ft and 20-ft spans, the finite element analyses and Equation 6 are almost identical. Other cases with discrete braces and different size stiffeners also show good agreement.

In general, stiffeners or connection details such as clip angles can be used to control distortion. For decks and through girders, the stiffener must be attached to the flange that is braced. Diaphragms are usually W shapes or channel sections connected to the web of the stringer or girders through clip angles, shear tabs or stiffeners. When full depth stiffeners or connection details are used to control distortion, the stiffener size that gives the desired stiffness can be determined from Equation 8. For partial depth stiffening illustrated in Figure 24, the stiffnesses of the various sections of the web ($\beta_i = \beta_c, \beta_s, \text{ or } \beta_r$) can be evaluated separately using Equation 9 with $h_i = h_c, h_s, \text{ or } h_r$,

$$\beta_i = \frac{3.3E}{h_i} \left(\frac{h}{h_i} \right)^2 \left(\frac{(N + 1.5h_i) t_w^3}{12} + \frac{t_s b_s^3}{12} \right) \quad (9)$$

and then combined as follows:

$$\frac{1}{\beta_{sec}} = \frac{1}{\beta_c} + \frac{1}{\beta_s} + \frac{1}{\beta_r} \quad (10)$$

The portion of the web within h_b can be considered infinitely stiff. The unstiffened depths, h_c and h_r , are measured from the flange centroid. For rolled sections, if the

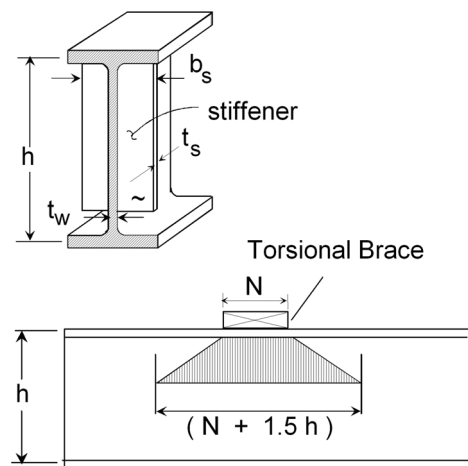

Fig. 23. Effective web width.

diaphragm connection extends over at least one-half the beam depth, then cross-section distortion will not be significant because the webs are fairly stocky compared to built-up sections. The depth of the diaphragm, h_s , can be less than one-half the girder depth as long as it provides the necessary stiffness to reach the required moment. Cross frames without web stiffeners should have a depth h_s of at least $\frac{3}{4}$ of the beam depth to minimize distortion. The location of a diaphragm or cross frame on the cross section is not very important; i.e. it does not have to be located close to the compression flange. The stiffeners or connection angles do not have to be welded to the flanges when diaphragms are used. For cross frames, β_s should be taken as infinity, as only h_t and h_c will affect distortion. If stiffeners are required for flange connected torsional braces on rolled beams, they should extend at least $\frac{3}{4}$ depth to be fully effective.

Equation 5 was developed for doubly-symmetric sections. The torsional bracing effect for singly-symmetric sections can be approximated by replacing I_y in Equation 5 with I_{eff} defined as follows:

$$I_{eff} = I_{yc} + \frac{t}{c} I_{yt} \quad (11)$$

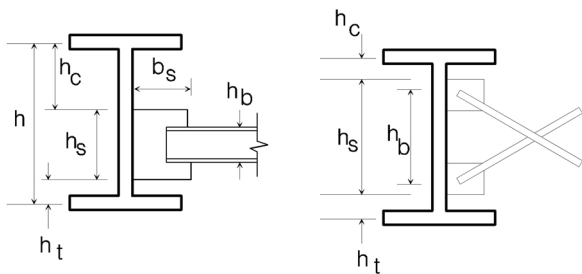

Fig. 24. Partially stiffened webs.

where I_{yc} and I_{yt} are the lateral moment of inertia of the compression flange and tension flange respectively, and c and t are the distances from the neutral bending axis to the centroid of the compression and tension flanges respectively, as shown in Figure 25(a). For a doubly symmetric section, $c = t$ and Equation 11 reduces to I_y . A comparison between the BASP solutions and Equations 5 and 11 for three different girders with torsional braces is shown in Figure 25(b). The curves for the W16x26 section show very good agreement. In the other two cases, one of the flanges of the W16x26 section was increased to $10 \times \frac{1}{2}$. In one case the small flange is in tension and in the other case, the compression flange is the smallest. In all cases Equation 11 is in good agreement with the theoretical buckling load given by the finite element analyses.

Equation 5 shows that the buckling load increases without limit as the continuous torsional brace stiffness increases. When enough bracing is provided, yielding will control the beam strength so M_{cr} cannot exceed M_y , the yield or plastic strength of the section. It was found that Equation 5 for continuous bracing could be adapted for discrete torsional braces by summing the stiffness of each brace along the span and dividing by the beam length to get an equivalent continuous brace stiffness. In this case M_{cr} will be limited to M_{bp} , the moment corresponding to buckling between the brace points. By adjusting Equation 5 for top flange loading and other loading conditions, the following general formula can be used for the buckling strength of torsionally braced beams:

$$M_{cr} = \sqrt{C_{bu}^2 M_o^2 + \frac{C_{bb}^2 \bar{\beta}_T E I_{eff}}{C_T}} \leq M_y \text{ or } M_{bp} \quad (12)$$

where

C_{bu} and C_{bb} = two limiting C_b factors corresponding to an

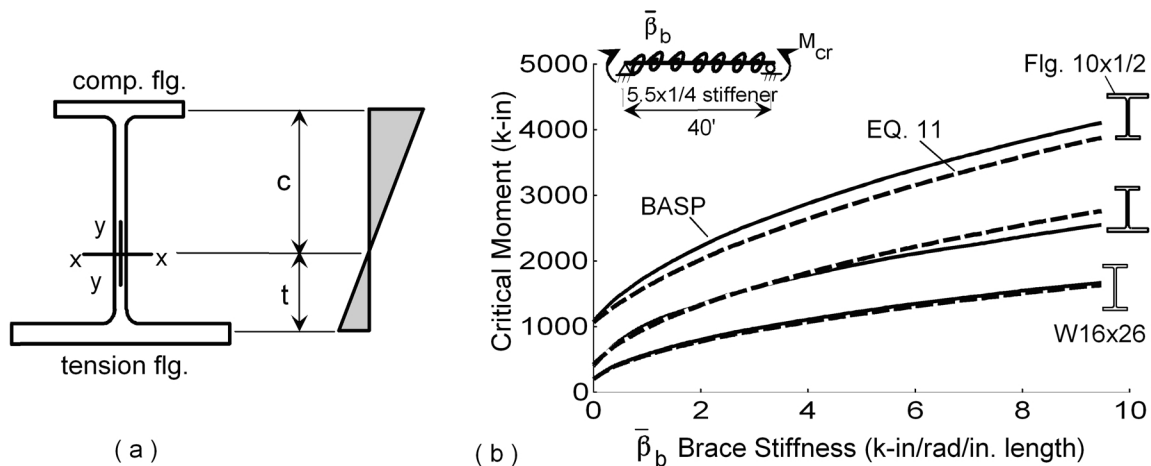

Fig. 25. Singly-symmetric girders.

unbraced beam (very weak braces) and an effectively braced beam (buckling between the braces)

C_T = top flange loading modification factor; $C_T = 1.2$ for top flange loading and $C_T = 1.0$ for centroidal loading

β_T = equivalent effective continuous torsional brace stiffness (in.-k/radian/in. length) from Equation 6. The following two cases illustrate the accuracy of Equation 12.

For the case of an unbraced beam with a concentrated load at the midspan as shown in Figure 26, $C_{bu} = 1.35$ (Galambos, 1988). Usually designers conservatively use $C_b = 1.0$ for this case. For the beam assumed braced at midspan, $C_{bb} = 1.75$ for a straight-line moment diagram with zero moment at one end of the unbraced length. These two values of C_b are used with any value of brace torsional stiffness in Equation 12. For accuracy at small values of brace stiffness the unbraced buckling capacity $C_{bu}M_o$ should also consider top flange loading effects. Equation 12 shows excellent agreement with the finite element solutions. With no stiffener, β_{sec} from Equation 8 is 114 in.-k/radian, so the effective brace stiffness β_T from Equation 6 cannot be greater than 114 regardless of the brace stiffness magnitude at midspan. Equations 6, 8 and 12 predict the buckling very accurately for all values of attached bracing, even at very low values of bracing stiffness. A $4 \times 1/4$ stiffener increased β_{sec} from 114 to 11,000 in.-k/radian. This makes the effective brace stiffness very close to the applied stiffness, β_b . With a $4 \times 1/4$ stiffener, the effective stiffness is 138 in.-k/radian if the attached brace stiffness is 140 in.-k/radian. The bracing equations can be used to determine the required stiffener size to reduce the effect of distortion to some tolerance level, say 5 percent.

In Figure 27 the approximate buckling strength, Equation 12, and the theoretical solution are compared for the case of a concentrated midspan load at the centroid with

three equally spaced braces along the span. Stiffeners at the three brace points prevent cross-section distortion so $\bar{\beta}_T = (3\beta_b/288 \text{ in.})$. Two horizontal cutoffs for Equation 12 corresponding to the theoretical moment at buckling between the braces are shown. The $K = 1.0$ limit assumes that the critical unbraced length, which is adjacent to the midspan load, is not restrained by the more lightly loaded end spans. To account for the effect of the end span restraint, an effective length factor $K = 0.88$ was calculated using the procedure given in the SSRC Guide (Galambos, 1988). Figure 27 shows that it is impractical to rely on side span end restraint in determining the buckling load between braces. An infinitely stiff brace is required to reach a moment corresponding to $K = 0.88$. If a K factor of 1 is used in the buckling strength formula, the comparison between Equation 12 and the finite element analysis is good. Equation 12 should not be used with K factors less than 1.0; the results will be unconservative at moments approaching the full bracing case. Similar results were obtained for laterally braced beams (Yura et al., 1992).

Torsional Brace Design

There are two basic torsional bracing systems shown in Figures 20 and 21: bending members represented by diaphragms, decks or floor beams; and trusses for the cross frames. The two systems can be correlated by noting that $M_{br} = F_{br}h_b$, where h_b is the depth of the cross frame. The term "brace forces" used hereinafter refers to both M_{br} and F_{br} . Equation 12 gives the relationship between brace stiffness and M_{cr} for an ideally straight beam. For beams with an initial twist, θ_o , it is assumed that the brace design requirements are affected in a similar manner as that developed for lateral bracing of beams with initial out-of-straightness. The required brace stiffness $\bar{\beta}_T^*$, which must be at least twice the ideal stiffness to keep brace forces small, can be obtained by rearranging Equation 12:

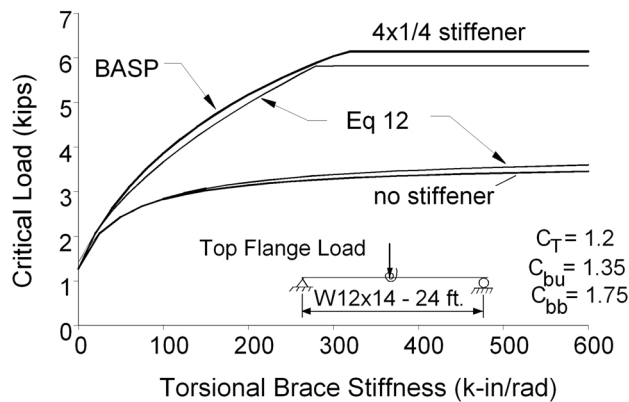

Fig. 26. Effect of stiffener.

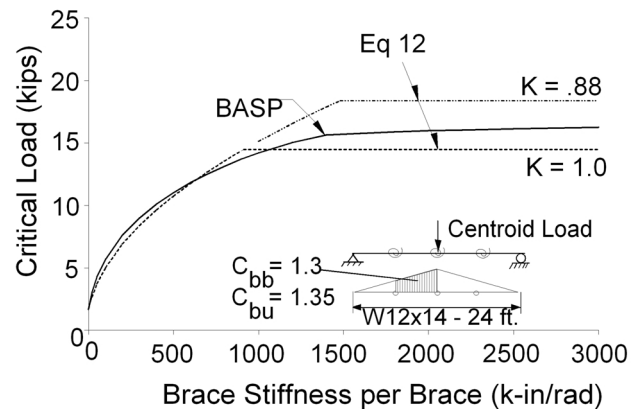

Fig. 27. Multiple discrete braces.

$$\bar{\beta}_T^* = 2 \left(M_{cr}^2 - C_{bu}^2 M_o^2 \right) \frac{C_T}{C_{bb}^2 E I_{eff}} \quad (13)$$

For discrete braces $\beta_T^* = \bar{\beta}_T^* L/n$. The torsional brace strength requirement is $M_{br} = \beta_T^* \theta_o$. An initial twist, $\theta_o = 0.002L_b/h$ is recommended. This value is consistent with the initial lateral displacement of $0.002L_b$ used in the development of the lateral bracing requirements. Equation 13 can be conservatively simplified by neglecting the $C_{bu}M_o$ term which will be small compared to M_{cr} at full bracing and by taking the maximum C_T , which is 1.2 for top flange loading. The simplified stiffness and brace force requirements are given in Chart 2.

Chart 2. Torsional Bracing Design Requirements

Stiffness:

$$\beta_T^* = \bar{\beta}_T^* L/n = 2.4LM_f^2 / (nEI_{eff}C_{bb}^2) \quad (14)$$

Strength:

$$M_{br} = F_{br} = 0.005LL_bM_f^2 / (nhEI_{eff}C_{bb}^2) \quad (15)$$

where

M_f = maximum beam moment

$I_{eff} = I_{yc} + (t/c)I_{yt}; = I_y$ for doubly symmetric sections (see Figure 25)

C_{bb} = moment diagram modification factor for the full bracing condition

L = span length

L_b = unbraced length

n = number of intermediate braces along the span

The available effective stiffness of the brace system β_T is calculated as follows:

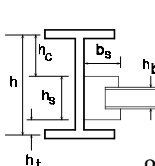

$$\frac{1}{\beta_T} = \frac{1}{\beta_c} + \frac{1}{\beta_s} + \frac{1}{\beta_t} + \frac{1}{\beta_b} + \frac{1}{\beta_g} \quad (16)$$

$$\beta_c, \beta_s, \beta_t = \frac{3.3E}{h_i} \left(\frac{h}{h_i} \right)^2 \left(\frac{(N + 1.5h_i)t_w^3}{12} + \frac{t_s b_s^3}{12} \right) \quad (17)$$

where

$h_i = h_c, h_s$ or h_t

N = bearing length (see Figure 23)

β_b = stiffness of attached brace (see Figs. 20 and 21);

$\beta_g = 24(n_g - 1)^2 S^2 EI_x / (L^3 n_g)$ (18)

where n_g is the number of interconnected girders (see Fig. 22)

The torsional brace requirements, Equations 14 and 15, must be adjusted for the different design specifications as

discussed earlier for the lateral brace requirements:

AISC-LRFD: $\beta_T \geq \beta_T^*/\phi$ where $\phi = 0.75; M_{br}$ —no change

AISC-ASD: $\beta_T \geq 3\beta_T^*$ where $3 = (1.5)^2/\phi; M_{allow} \geq 1.5M_{br}$

AASHTO-LFD: $\beta_T \geq \beta_T^*$ no change; M_{br} —no change

Torsional Brace Design Examples

In Example 3 a diaphragm torsional bracing system is designed by the AASHTO-LFD specification to stabilize the five steel girders during construction as described in Examples 1 and 2 for lateral bracing. The strength criterion, Equation 15, is initially assumed to control the size of the diaphragm. Both yielding and buckling of the diaphragm are checked and a C10×15.3 section has sufficient strength to brace the girders. It appears that a smaller channel section could be used but stiffness must also be checked. The stiffness of the C10×15.3 section, 195,500 in.-k/radian, is much greater than required, but the connection to the web of the girder and the in-plane girder flexibility also affect the stiffness. In this example, the in-plane girder stiffness is very large and its affect on the brace system stiffness is only 2 percent. In most practical designs, except for twin girders, this effect can be ignored. If a full depth connection stiffener is used, a $\frac{3}{8} \times 3\frac{1}{2}$ - in. plate is required. The weld design between the channel and the stiffener, which is not shown, must transmit the bracing moment of 143 kip-in. If a smaller diaphragm is used, the stiffener size will increase.

The 40-in. deep cross frame design in Example 4 required a brace force of 3.6 kips from Equation 15. The factored girder moment of 1,211 kip-ft. gives an approximate compression force in the girder of $1,211 \times 12/49 = 296$ kips. Thus, the brace force is 1.2 percent of the equivalent girder force in this case. The framing details provide sufficient stiffness. The 3-in. unstiffened web at the top and bottom flanges was small enough to keep β_{sec} well above the required value. For illustration purposes, a 30-in. deep cross frame attached near the compression flange is also considered. In this case, the cross frame itself provides a large stiffness, but the 14-in. unstiffened web is too flexible. Cross-section distortion reduces the system stiffness to 16,900 in.-k/radian, which is less than the required value. If this same cross frame was placed at the girder midheight, the two 7-in. unstiffened web zones top and bottom would be stiff enough to satisfy the brace requirements. For a fixed depth of cross frame, attachment at the mid-depth provides more effective brace stiffness than attachment close to either flange.

CLOSING REMARKS AND LIMITATIONS

Two general structural systems are available for bracing beams, lateral systems and torsional systems. Torsional bracing is less sensitive than lateral bracing to conditions

such as top flange loading, brace location, and number of braces, but more affected by cross-section distortion. The bracing recommendations can be used in the inelastic buckling range up to M_p if the M_f form of the lateral brace stiffness equation is used (Ales and Yura, 1993).

The recommendations do not address the bracing requirements for moment redistribution or ductility in seismic design. The bracing formulations will be accurate for design situations in which the buckling strength does not rely on effective lengths less than one. Lateral restraint provided by lightly loaded side spans should, in general, not be considered because the brace requirements would be much larger than the recommendations herein. Also, laboratory observations in the author's experience (usually unplanned failures of test setups) show that brace forces can be very large when local flange or web buckling occurs prior to lateral instability. After local buckling, the cross section is unsymmetrical and vertical loads develop very significant out of plane load components. The bracing recommendations do not address such situations.

In the 1999 AISC-LRFD Specification (AISC, 1999), stability bracing requirements are specified for the first time for frames, columns, and beams. The research and recommendations presented in this paper provide a background and commentary for the beam bracing provisions that were adopted in that Specification.

ACKNOWLEDGMENTS

The Texas Department of Transportation and the American Iron and Steel Institute sponsored most of the research that is reported herein. The help of many students is gratefully acknowledged, especially J. Ales, R. Gedies, T. Helwig, B. Phillips, S. Raju and S. Webb who conducted much of the experimental research that support the recommendations contained in this paper.

REFERENCES

- Akay, H. U., Johnson, C. P., and Will, K. M. (1977), "Lateral and Local Buckling of Beams and Frames," *Journal of the Structural Division*, ASCE, ST9, September, pp. 1821-1832.
- Ales, J. M. and Yura, J. A. (1993), "Bracing Design for Inelastic Structures", *Proceedings*, SSRC Conference—"Is Your Structure Suitably Braced?" April 6-7, Milwaukee, WI, pp. 29-37.
- American Institute of Steel Construction, Inc. (AISC) (1999), *Load and Resistance Factor Design Specification for Structural Steel Buildings*, Chicago, IL.
- Choo, K. M. (1987), "Buckling Program BASP for Use on a Microcomputer", MS Thesis presented to The University of Texas at Austin, May.
- Galambos, T. V., Ed. (1988), *Guide to Stability Design Criteria for Metal Structures*, Structural Stability Research Council, 4th Edition, New York, John Wiley & Sons.
- Helwig, T. A., Yura, J. A., and Frank, K. H. (1993), "Bracing Forces in Diaphragms and Cross Frames," *Proceedings*, SSRC Conference—"Is Your Structure Suitably Braced?" April 6-7, Milwaukee, WI, pp. 129-137.
- Kirby, P. A. and Nethercot, D. A. (1979), *Design for Structural Stability*, New York, John Wiley & Sons.
- Lindner, J. and Schmidt, J. S. (1982), "Biegedrillknicken von I-Trägern unter Berücksichtigung wirklichkeitsnaher Lasteinleitung (Buckling of I-Girders Under Realistic Load Applications)", *Der Stahlbau*, 51, H.9, S. 257-263.
- Medland, I. C. (1980), "Buckling of Interbraced Beam Systems", *Engineering Structures*, 2, April, pp. 90-96.
- Milner, H. R. (1977), "Design of Simple Supported Beams Braced Against Twisting on the Tension Flange," *Civil Engineering Transactions*, Institute of Engineers, Australia, CE 19(1), pp. 84-91.
- Nakamura, T. (1988), "Strength and Deformability of H-Shaped Steel Beams and Lateral Bracing Requirements," *J. Constructional Steel Research*, 9, pp. 217-228.
- Nakamura, T. and Wakabayashi, M. (1981), "Lateral Buckling of Beams Braced by Purlins," *Inelastic Instability of Steel Structures and Structural Elements*, U.S. Japan Seminar, Y. Fujita and T. V. Galambos, Ed.
- Nethercot, D. A. (1989), "The Design of Bracing Systems for Plate Girder Bridges," *Structural Eng/Earthquake Eng.*, Vol. 6, No. 1, Review, (Proc JSCE, No 404 / I-11), April, pp. 23-34.
- Plaut, R. S. (1993), "Requirements for Lateral Bracing of Columns with Two Spans," *Journal of Structural Engineering*, ASCE, Vol. 119, No. 10, October, pp. 2913-2931.
- Raju, S., Webb, S., and Yura, J. (1992), "Bracing Effects of Bridge Decks," *Proceedings*, 9th Annual International Bridge Conference, Pittsburgh, June 15, 9 p.
- Taylor, A. C. and Ojalvo, M. (1966), "Torsional Restraint of Lateral Buckling," *Journal of the Structural Division*, ASCE, ST2, April, pp. 115-129.
- Timoshenko, S. and Gere, J., (1961), *Theory of Elastic Stability*, New York: McGraw-Hill.
- Tong, G. S., and Chen, S. H., 1988, "Buckling of Laterally and Torsionally Braced Beams", *Journal of Constructional Steel Research*, 11, pp. 41-55.
- Trahair, N. S. and Nethercot, D. A. (1982), "Bracing Requirements in Thin-Walled Structures," *Developments in Thin-Walled Structures-Vol. 2*, J. Rhodes and A. C. Walker - Ed., Elsevier, pp. 93-129.
- Wakabayashi, M. and Nakamura, T. (1983), "Buckling of Laterally Braced Beams", *Eng. Struct.*, 5, April, pp. 108-118.
- Wang, Y. C. and Nethercot, D. A., (1989), "Ultimate Strength Analysis of Three-Dimensional Braced I-Beams", *Proceedings, Institution of Civil Engineers*, London, Part 2, 87, March, pp. 87-112.
- Winter, G. (1960), "Lateral Bracing of Columns and Beams," *ASCE Transactions*, Vol. 125, pp. 809-825.
- Yura, J. A. (1995), "Bracing for Stability-State-of-the-Art", *Proceedings*, Structures Congress XIII, ASCE, Boston, MA, April, pp. 1793-1797
- Yura, J. A. and Phillips, B. (1992), "Bracing Requirements for Elastic Steel Beams," Report No. 1239-1, Center for Transportation Research, University of Texas at Austin, May, 73 p.
- Yura, J. A., Phillips, B., Raju, S., and Webb, S. (1992), "Bracing of Steel Beams in Bridges," Report No. 1239-4F, Center for Transportation Research, University of Texas at Austin, October, 80 p.

DESIGN EXAMPLES

Lateral Bracing

LATERAL BRACING - DESIGN EXAMPLE 1

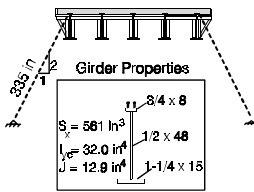

Girder Properties
 $S_x = 561 \text{ in}^3$
 $I_x = 32.0 \text{ in}^4$
 $J = 12.9 \text{ in}^4$
 3/4 x 8
 1/2 x 48
 1-1/4 x 15

Span = 80 ft.; 10 in. concrete slab
 5 girders @ 8 ft spacing, A36 steel

Design a lateral bracing system to stabilize the girders during the deck pour. Use the external tension system shown. The form supports transmit some load to the bottom flange so assume centroid loading.

Use Load Factor Design for the construction condition - L.F. = 1.3

Loads: Steel girder: $A = 48.75 \text{ in}^2$, $w_t = 165 \text{ lb/ft}$
 Conc. slab: $8' \times \frac{10}{12} \times 150 \text{ lb/ft}^3 = 1000 \text{ lb/ft}$
 $w = 1165 \text{ lb/ft} = 1.165 \text{ k/ft}$

$M = \frac{1}{8} w L^2 \times L.F. = \frac{1}{8} (1.165) (80)^2 \times 1.3 = 1211 \text{ k-ft}$
 $M_y = 36 (561) / 12 = 1682 \text{ k-ft} > 1211 \text{ k-ft}$

Try 4 lateral braces @ 16-ft spacing

Check lateral buckling - center 16-ft is most critical (AASHTO 10-102c)

$$M = 91 \times 10^6 (1.0) \frac{32.0}{16 \times 12} \sqrt{0.772 \frac{12.9}{32.0} + 9.87 \left(\frac{50}{16 \times 12}\right)^2}$$

= 15020000 lb-in = 1251 k-ft > 1211 k-ft **4 braces required**

Brace Design: Use the full bracing formula - discrete system
 - See Eq 2 & 3

$$P_f = \frac{\pi^2 (29000) (32.0)}{(16 \times 12)^2} = 248 \text{ kips}; N_f = 4 - \frac{2}{4} = 3.5; C_b = 1.0; C_L = 1.0$$

$$\beta'_L = 2 \frac{3.5 (248) (1.0) (1.0)}{16 \times 12} = 9.04 \text{ k/in. for ea. girder} = 45.2 \text{ k/in. for 5 girders} = F_d A$$

Brace stiffness = $\cos^2 \theta \left(\frac{AE}{L}\right)_b = \frac{A_b (29000)}{(\sqrt{5})^2 335} = 45.2 \text{ k/in.}$

Brace Strength: (A36 steel)
 $F_{br} = 0.01 (5) (1211 \times 12 / 49.0) = 14.83 \text{ k}$
 five girders
 $A_b F_y = 14.83 / \cos \theta; A_b = \frac{14.83 \sqrt{5}}{36} = 0.92 \text{ in}^2$

Torsional Bracing

TORSIONAL BRACING - DESIGN EXAMPLE 3

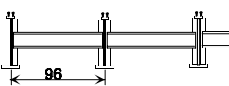

Same as Example 1 except use the diaphragm system shown. In Ex. 1, four lateral braces were required which gave $M_y = 1251 \text{ k-ft}$, just 3% greater than the required moment. Since torsional braces will impose some additional vertical forces on the girders as shown in Fig. 22, probably five braces should be used. However, for comparison with Examples 1 & 2, a four-brace system will be designed. $M_{req'd} = 1211 \text{ k-ft}$ (see Ex. 1)

Girder Properties
 $h = 49.0$, $c = 30.85$, $t = 18.15 \text{ in}$
 $I_x = 17500$, $I_y = 32.0$, $I_{xt} = 352 \text{ in}^4$

Eq. (11): $I_{eff} = 32 + \frac{18.15}{30.85} 352 = 239 \text{ in}^4$

Eq. (15): $M_{br} = \frac{0.005 (80 \times 12) (1211 \times 12)^2 (16 \times 12)}{4 (29000) 239 (1.0)^2 (49)} = 143 \text{ in-k}$ **Req'd $S_x = 143/36 = 3.97 \text{ in}^3$**

Try C10 x 15.3 - $I_x = 67.4 \text{ in}^4$, $S_x = 13.5 \text{ in}^3$, $t_f = 0.436 \text{ in}$, $b = 2.60 \text{ in}$, $J = 0.21 \text{ in}^4$

Check lateral buckling of the diaphragm
 $I_{yc} = (2.60)^3 (0.436) / 12 = 0.639 \text{ in}$

$M_y = 91 \times 10^6 (2.3) \frac{0.639}{96} \sqrt{\frac{.772 (0.21)}{0.639} + \left(\frac{\pi 10}{96}\right)^2}$ (AASHTO 10-103c)

= 837000 lb-in = 837 in-k > $M_y = 13.5 (36) = 486 > 143 \text{ in-k}$, OK

Check stiffness: Eq. (14); $\beta_{T req'd} = \frac{2.4 (80 \times 12) (1211 \times 12)^2}{4 (29000) 239 (1.0)^2} = 17550 \text{ in-k/radian}$

The stiffness of the diaphragms on the exterior girders is $6EI_{br}/S$. Since there are diaphragms on both sides of each interior girder, the stiffness is $2 \times 6EI_{br}/S$. The average stiffness available to each girder is $(2 \times 6 + 3 \times 12)/5 = 9.6 EI_{br}/S$.

$\beta_b = 9.6 (29000) 67.4 / 96 = 195500 \text{ in-k/radian}$

Girder: Eq. (18) $\beta_g = \frac{24 (5.1)^2 29000 (96)^2 17500}{5 (80 \times 12)^3} = 406000 \text{ in-k/radian}$

Distortion: From Eq. (16) and Eq. (17) determine the required stiffener width, $t_s = 3/8 \text{ in}$

From Eq. (16) $\frac{1}{17550} = \frac{1}{195500} + \frac{1}{406000} + \frac{2}{\beta_s}$; $\beta_s = 40500 \text{ in-k/radian}$

From Eq. (17) $40500 = \frac{3.3 (29000) \left(\frac{49}{19.5}\right)^2 \left(1.5 \times 19.5 \times 0.5^3 + \frac{0.375 b_s^3}{12}\right)}{19.5}$

$b_s = 3.17 \text{ in.}$ - Use 3/8 x 3-1/2 stiffener

LATERAL BRACING - DESIGN EXAMPLE 2

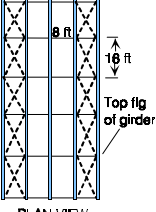

Same as Example 1 except the bracing system is a relative system - a top flange horizontal truss. Each truss stabilizes 2-1/2 girders. The X-bracing is designed as a tension only system so only one diagonal is active within each panel. The unbraced length of the girder flange is 16 ft which was checked in Example 1.

Brace stiffness:
 $\beta'_L = \frac{2 P_f C_b C_L}{L_b} = \frac{2 (248) 1.0 (1.0)}{16 \times 12} = 2.58 \text{ k/in for ea. girder} = 6.45 \text{ k/in for 2 1/2 girders}$

$\cos^2 \theta \left(\frac{AE}{L}\right)_b = \left(\frac{1}{\sqrt{5}}\right)^2 \frac{A_b (29000)}{(8 \times 12 \times \sqrt{5})} = 6.45 \text{ k/in}; A_b = 0.239 \text{ in}^2$

Brace strength: $F_{br} = 0.004 (2/12) \frac{(1211 \times 12)}{49} = 2.97 \text{ kips}$
 $A_b F_y = 2.97 \sqrt{5}$; $A_b = \frac{2.97 \sqrt{5}}{36} = 0.184 \text{ in}^2$

Stiffness controls the brace size; $9/16 \phi$ OK $A = 0.248 \text{ in}^2$

TORSIONAL BRACING - DESIGN EXAMPLE 4

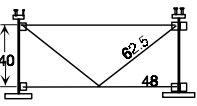

Same as Example 3, but use cross frames. Make all member sizes the same. A K-frame system will be considered using double angle members welded to connection gusset plates. Member lengths are shown in inches. Use four crossframes. See Examples 1 and 3 for section properties. Use A36 steel.

Assume brace strength criterion controls - Eq. (15)
 $F_{br} (40) = 143 \text{ in-k}$ (see Example 3); $F_{br} = 3.6 \text{ kips}$

From Fig. 21: Max force = diagonal force = $\frac{2 F_{br} L \phi}{S} = \frac{2 (3.6) 82.5}{96} = 4.7 \text{ kips - comp}$

Try 2L-2 1/2 x 2 1/2 x 1/4 $r_x = .769 \text{ in.}$, $A = 2.38 \text{ in}^2$, $L/r = 82.5 / .769 = 81.2$

$F_{cr} = 36 \left(1 - \frac{36}{4 \pi^2 29000} (81.2)^2\right) = 28.5 \text{ ksi}$ (AASHTO 10-150 and 10-151)
 $P_u = 0.85 (2.38) 28.5 = 57.7 > 4.7 \text{ k}$ OK

Check brace stiffness:
 Eq. (14); $\beta_{T req'd} = 17550 \text{ in-k/radian}$ - see Example 3

Fig. 21: $\beta_b = \frac{2 (29000) (96)^2 (40)^2 (2.38)}{8 (82.5)^3 + (96)^3} = 717000 \text{ in-k/radian}$

Girder: $\beta_g = 406000 \text{ in-k/radian}$ - see Example 3

$\beta_c = \beta_t = \frac{3.3 (29000) \left(\frac{49}{3.0}\right)^2 \left(\frac{1.5 (3.0) (.5)^3}{12}\right)}{3.0} = 399000 \text{ in-k/radian}$

Eq. (16): $\frac{1}{\beta_T} = \frac{1}{717000} + \frac{1}{406000} + \frac{2}{399000}$; $\beta_T = 113000 > 17550 \text{ in-k/rad}$ OK

Evaluate the cross frame shown below

$\beta_b = \frac{2 (29000) (96)^2 (30)^2 (2.38)}{8 (56.6)^3 + (96)^3} = 490000 \text{ in-k/radian}$

$\beta_t = \frac{3.3 (29000) \left(\frac{49}{14.0}\right)^2 \left(\frac{1.5 (14.0) (.5)^3}{12}\right)}{14.0} = 18300 \text{ in-k/radian}$

$\frac{1}{\beta_T} = \frac{1}{490000} + \frac{1}{406000} + \frac{1}{18300}$; $\beta_T = 16900 < 17550 \text{ in-k/rad}$ NG