

Connections: Art, Science, and Information in the Quest for Economy and Safety

DR. WILLIAM A. THORNTON

INTRODUCTION

Connections are an extremely important part of the final configuration of a steel structure. Many, if not most, collapses are caused by inadequate connections. The constructed cost of a steel frame is heavily dependent on the connections used, both the type of connection and how they are configured. Yet, connections are often an afterthought. Commercially available software will pretty much automatically design the members of the frame, but there is no commercially available software that will do the same for the connections. In fact, the frame design software chooses "optimal" members, usually least weight, with no regard whatsoever as to how these members will impact on the connections.

The emphasis in engineering schools is similar to that of commercially available design software, i.e., it is on the design of members. Very little work is done on connections at the undergraduate level and probably also at the graduate level. Connections are considered by many professors as essentially trivial in a mathematical sense. Very sophisticated and mathematically elegant solutions can be prescribed for member and frame design; e.g., lateral torsional buckling of members, and the direct stiffness method for frames. Connections, on the other hand, are thought to be designed by no more sophisticated analysis than counting bolts and determining weld lengths. This is not true except for the simplest connections. While there are essentially only three types of members in a structural frame (beams, columns, and beam-columns), there is an almost infinite variety of connections depending on frame geometry. For this reason, connection design is actually more interesting than member design, because this great variety often requires the designer to rely on intuition and art as well as science.

As mentioned above, connections are often an afterthought. In many engineering offices, once the frame is designed and "on paper," the drawings are ready to be "released for construction." Connections are handled by a series of typical details and general notes which refer to AISC manuals. Typical notes for shear connections might make reference to full depth connections or the Uniform Design

Load (UDL): For moment connections, the notes might say use stiffeners and doublers as required, and design for the strength of the beams. For bracing connections, a typical detail might be shown with a statement to design for all eccentricities. It is the primary purpose of this paper to show by anecdotal examples, i.e., "war stories," that this approach to connections can be both uneconomical and unsafe. A secondary purpose is to give the motivation behind a new method of bracing design called the Uniform Force Method. Examples will be given of shear connections, bracing connections, and moment connections.

SHEAR CONNECTIONS

Shear connections are a subject where information is the primary quantity lacking on most jobs. These connections have been heavily studied over the years, and other than questions regarding ductility and robustness, are well understood.

Shear connections are the most common connection on all jobs. Ideally, the engineer should give the shear for every beam end. While this may appear to be a lot of extra work, it is not as difficult as it first seems since the loads are known from sizing the beams. Why not put them on the drawing? (In addition to helping the fabricator, having the loads used in the original design right on the drawing is very handy for future renovations.) If the loads are shown for every beam end, there is very little room for error, and the connections will be as economical as possible.

However, instead of actual loads, most jobs these days have one or more of the statements regarding shear connections:

- Item 1. All shear connections shall contain the maximum possible number of rows of bolts;
- Item 2. Design all shear connections for one-half UDL;
- Item 3. Design all shear connections for the shear capacity of the beam;
- Item 4. Minimum design loads for standard rolled shapes, unless noted otherwise:

W8 C8	10 kips	W21	65 kips
W10 C10	15 kips	W24	75 kips
W12 C12	25 kips	W27	90 kips
W14 C15	35 kips	W30	125 kips
W16	45 kips	W33	140 kips
W18	55 kips	W36	175 kips

Dr. William A. Thornton is chief engineer, Cives Steel Co. and president, Cives Engineering Corp., Roswell, GA.

Let's consider each of these.

Item 1

Item 1 requires "full depth" connections.

The fabricator assumes the engineer has reviewed his design and the capacity of these connections will exceed the actual loads in all cases. But in many cases, these will be uneconomical, as with long span beams. In other cases, they may be unsafe.

Suppose a beam has a large cope, as when connecting a small beam to a large one (see Figure 1). This may greatly reduce the capacity of the full depth connection because of the reduced beam section. Has the engineer considered this, or has he reviewed his drawings by checking the actual load against the capacity of a full depth connection on an uncoped beam? It is very likely that he has done the latter. As a second example, consider steel at different elevations.

Figure 2 shows a "full depth" connection for the upset W18x35. The capacity of this "full depth" connection is 20k whereas a true full depth connection for the W18x35 (Figure 3) is 49k. Will the engineer realize this if he specifies "use the maximum possible number of rows"?

Item 2

If in-fill beams frame near the ends of a main beam, the UDL method can be unsafe. If beams are short, it will be uneconomical. Figure 4 shows a floor framing plan. All beam shear connections are contractually required to be designed for one-half UDL. The three W10x22s framing between the W36x170 and the W36x230 are 3-ft. long. The one-half UDL reaction is 61.8k! Of course, this is ridiculous—but the fabricator is contractually obliged to supply it if the engineer insists, and we have done jobs where the engineer did just that. Figure 5 shows the resulting connection. Note that the shear capacity of a W10x22 is only 35.4 kips, so designing for 61.8 kips is doubly ridiculous and leads to a discussion of Item 3.

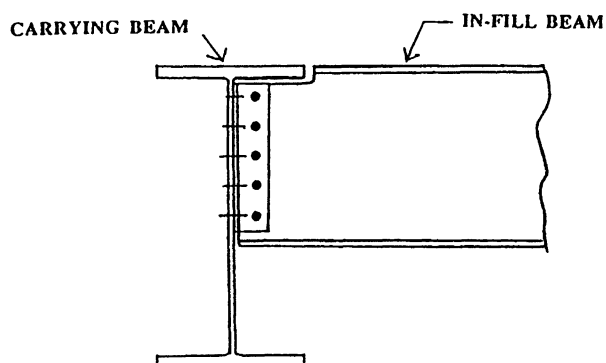

Fig. 1. Usual beam to beam connection top of steel at common elevation.

Item 3

Item 3 requires the connection to develop the shear capacity of the beam, but this is impossible with the usual shear connections (single clips, double clips, shear end plate, shear tab) unless the beam is haunched or web doublers are used.

Also, since most beams are coped, just what is the "shear capacity" of the beam? Is it the uncoped capacity (35.4 kips for the W10x22 shown previously) or should the capacity of what is left be used?

It's clear that Item 3 is ambiguous, which can lead to errors affecting safety as well as result in ridiculous designs. In Figure 6, the W10x22 of Figure 4 has end connections good for 35.4 kips, which means the W10x22 is capable of supporting 35.4 tons! Obviously, these W10x22s are just intended to reduce the unbraced length or provide decking support. If a real load of 35.4 tons must be carried, a short W18x35 with five rows of bolts would be cheaper and safer.

Item 4

While at first glance, Item 4 appears to be innocuous, try to develop 15k in the W10x22 shown previously. Figure 7 results.

Single Angles and UDL

The uniform design load UDL is a great crutch of the engineer because it allows him to issue design drawings without putting the beam reactions on the drawings. Instead, often the fabricator is told to design the beam end connections for one-half UDL, or some other percentage to account for composite design, unless greater reactions are shown. Unless concentrated loads are located very near the beam ends, UDL reactions are generally very conservative. Because the reactions are too large, extremely strong connections, such as double framing angles, will often be required.

Single angles, because the bolts are in single shear, will have about half the strength of double clips for the same number of rows of bolts. But if actual reactions are given, it

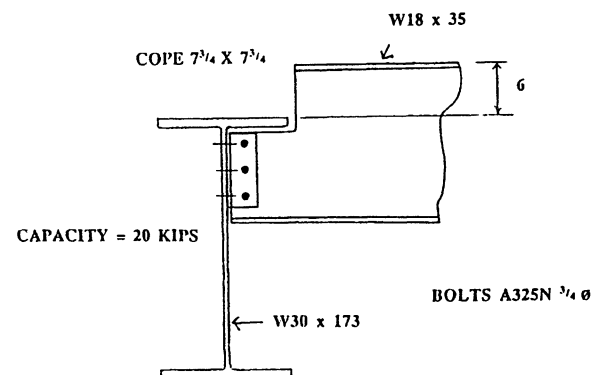

Fig. 2. "Full depth" connection for upset beam.

will almost always be found that a single angle connection will work, perhaps with a couple of extra rows of bolts.

Figure 8 is part of an industrial building with dead load of 140 psf and live load of 250 psf. Beam 1, of Figure 8 is shown in Figure 9. The total load on Beam 1 is 82 kips and the actual reactions are thus 41 kips. The one-half UDL reaction is 45 kips, which is pretty close. Now look at the connections. The minimum double clip connection on this coped beam has four rows and is good for 81 kips, almost twice the actual reaction. Many designers routinely require "full depth" connections, i.e. six rows. The six row double dip connection is good for 166 kips, almost three times the actual reaction. However, a five row single angle is good for 52 kips, which is okay for the actual and the one-half UDL reactions.

As this example illustrates, single angles will work even in heavy industrial applications, and they are much less expensive than double clips, especially for erection. In Figure 10, the connections for this W24x55 beam have the same strength and have a differential cost of \$10 for fabrication. But, including erection, the single angle beam costs approximately \$25 less than the double clip beam. For a 30-story building, 200

ft. x 200 ft. with 25-ft. bays and 200 beams per floor with single angles, there is a savings of $200 \times 30 \times 25 = \$150,000$.

Returning to Figure 8, suppose Beam 1 is subjected to the same load of 82 kips total, but 32 of the 82 is a concentrated load located at mid-span, such as from a vessel. Figure 11 shows the actual reaction of the beam, now a W24x76, is still 41 kips, while the one-half UDL reaction is 56 kips—which is 37 percent greater than the actual reaction. This means while a five row single angle connection is okay for the actual reaction, a six row connection with a capacity of 66 kips would be required for the one-half UDL reaction. Figure 12 shows the disparity between actual and one-half UDL reactions for Beam 2. Again, single angles are sufficient.

BRACING CONNECTIONS

Bracing connections are subject where the art and science of connection design can be used to achieve a safe and efficient design. They are also an area where missing or misleading information can lead to drastically unsafe connections or connections which are grossly over-designed.

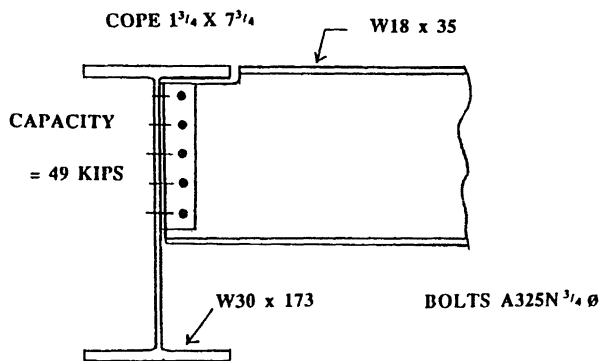

Fig. 3. Normal full depth connection.

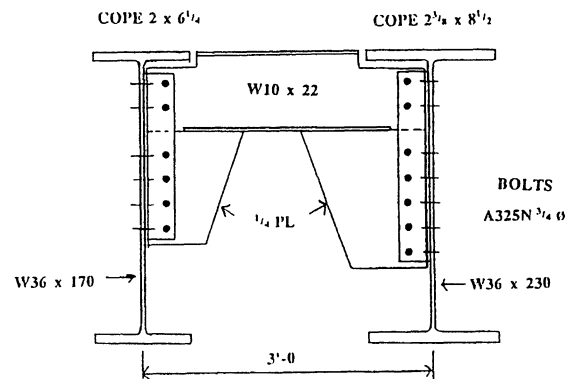

Fig. 5. Section AA of Figure 4 W10x22 to carry $\frac{1}{2}$ UDL = 61.8 kips reaction each end.

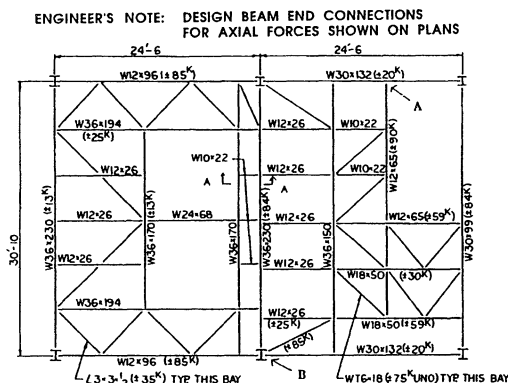

Fig. 4. Ambiguous forces for connection design.

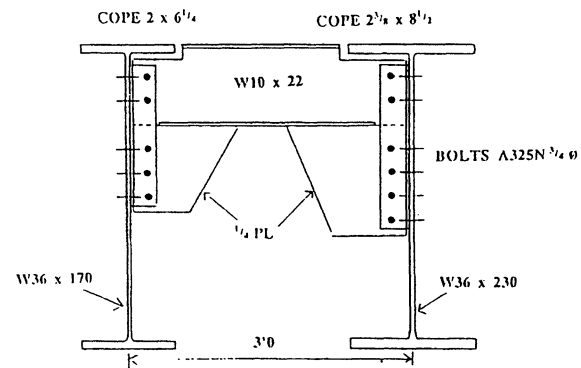

Fig. 6. Section AA of Figure 4 W10x22 to carry maximum uncoped shear capacity of 35.4 kips as reactions at each end.

Art and Science

Figure 13 shows a bracing connection design method which satisfies all of the requirements for equilibrium for the gusset, the beam, and the column. It includes consideration of all eccentricities and it is simple to use because all forces acting between the gusset and the beam and column are known before the size of the gusset is known. It has been referred to as the KISS method by a detailer who was impressing upon his people the necessity of getting the shop drawings "out the door." Thus, the sarcastic comment to "Keep It Simple, Stupid!," or use the KISS method. Unfortunately, while this method is a boon to the detailer, it is a bane to the fabricator and owner. It results in large and expensive connections. Also, the engineer and owner do not like it when, if there are four gussets in a building panel, they almost meet at the center. Also, the load paths through this gusset, beam, and column are very unnatural and inefficient as will be shown.

Beginning about 15 years ago, AISC began to address this problem with a research program at the University of Arizona. This program resulted in published work by Richard (1986) which contained figures similar to Figure 14. In this Figure,

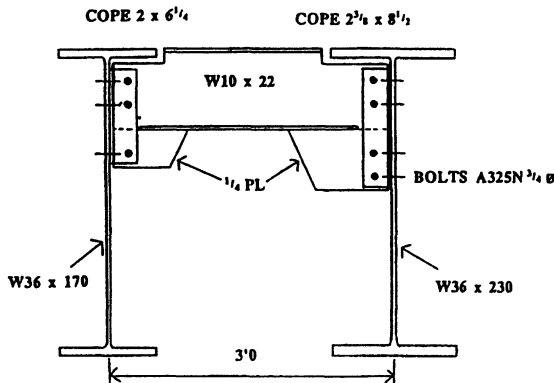

Fig. 7. Section AA of Figure 4 W10x22 to carry 15 kip reaction each end.

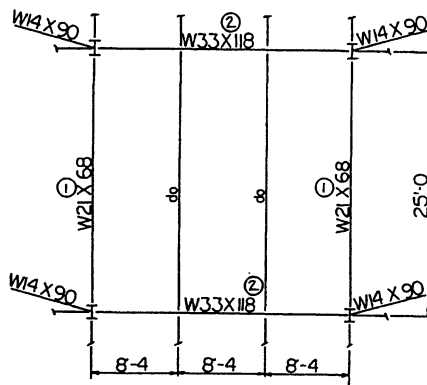
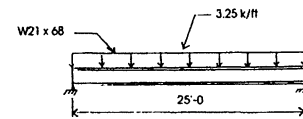

Fig. 8. Partial plan of industrial building floor.

the resultant forces on the gusset edges for a wide variety of gusset edge support conditions are seen to fall within the envelopes shown. The edge resultants appear to intersect with the line of action of the brace at a point on this line on the other side of the working point (WP) from the gusset. Note that no couples were required in Figure 14. This data from Richard is the genesis of the author's development of what has come to be called the Uniform Force Method (Thornton 1991, 1992 and AISC 1992, 1994). The method is shown in Figure 15A. Figure 15B shows a force distribution which captures the essence of the distributions given "fuzzily" in Figure 14. In other words, a force structure is imposed on Richard's data. In order to test the efficacy of this structure, the data of six full scale tests were filtered through it. The tests were performed by Chakrabarti and Bjorhovde, (1983, 1985) and Gross and Cheok (1988, 1990). Typical test specimens are shown in Figures 16 and 17. The limit states considered in the filtering process are given in Tables 1 and 2. Table 3 shows the results. For the Chakrabarti/Bjorhovde tests, excellent agreement is achieved. The ratio of test capacity to predicted capacity is close to but slightly larger than unity as



BEAM	SECTION	LOADS			REACTIONS		CONNECTIONS					
		UNIFORM K/FT	CONC. K/FT	TOTAL K/FT	ACTUAL K/FT	±UDL K/FT	DOUBLE CLIPS			SINGLE CLIP		
						MIN ROWS	CAP (KIPS)	MAX ROWS	CAP (KIPS)	NUMBER OF ROWS	CAP (KIPS)	
1	W21x68	3.25	0	82	41	45	1	81	6	116	5	52

BOLTS 7/8" A 325N, CLIPS 4 X 3 1/2 X 3/8

Fig. 9. Comparisons for beam 1 of Figure 8—uniform load.

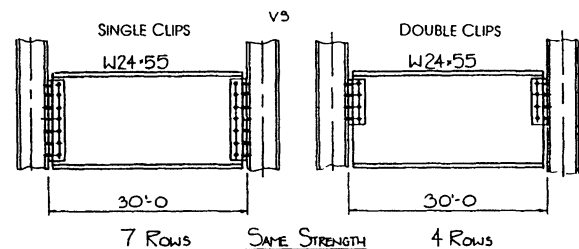

FABRICATION - \$10 PER BEAM LESS FOR SINGLE CLIPS
 ERECTION - \$15 PER BEAM LESS FOR SINGLE CLIPS
 TOTAL COST REDUCTION \$25 PER BEAM USING SINGLE CLIPS

Fig. 10. Cost comparison same strength single and double clips.

Limit State Type	Limit State Number
Bolt Shear Fracture	1
Bolt Shear/Tension Fracture	2
Whitmore Yield	3
Whitmore Buckling	4
Tearout Fracture	5
Bearing	6
Gross Section Yield	7
Net Section Fracture	8
Fillet Weld Fracture	9
Beam Web Yield (beyond <i>k</i> distance)	10
Bending (including Prying Action) Yield	11
Bending (including Prying Action) Fracture	12

is desired. The agreement for the Gross/Cheek tests is not as good, but the method is clearly conservative. The reason for the poorer agreement in this second series of tests is due to frame action. The tests include it but the Uniform Force Method does not. Perhaps frame action can be included in some future design method, but for the present, the data available indicate that its neglect is conservative.

An Example: The Kiss Method vs. the Uniform Force Method

Figure 18 shows the design example. The column is a W14x605, the beam a W18x106, and the brace a W12x65 with 450 kips. Figure 19 gives the completed designs for the KISS Method and the Uniform Force Method. A cost comparison indicates that the KISS design costs \$840 while that of the Uniform Force Method costs \$658. Thus, the KISS Method costs about 28 percent more in addition to being a much more intrusive (to ductwork, piping, etc.) connection.

To see the effect on a project of using the KISS Method rather than the Uniform Force Method, consider a 40 story building with eight bracing connections per story. If all these connections were similar to those shown in Figure 18, the cost

Connection Interface	Connection Element	Limit States
Brace to Gusset (A)	Bolts to Gusset	1
	Gusset	3,4,5,6
	Bolts to Brace	1
	Brace	5,6,7,8
Gusset to Beam (B)	Gusset	7
	Fillet Weld	9
	Beam Web	10
Gusset to Column (C)	Bolts to Gusset	1
	Fillet Weld to Gusset	9
	Gusset	6,7,8
	Bolts to Column	2
	Clip Angles	6,7,8,11,12
Beam to Column (D)	Column	6,11,12
	Bolts to Beam Web	1
	Fillet Weld to Beam Web	9
	Beam Web	6,7,8
	Bolts to Column	2
	Clip Angles	6,7,8,11,12
Column	6,11,12	

¹See Figure 16 for Interface Identification

of using the KISS Method rather than the Uniform Force Method would be $(840 - 658) \times 8 \times 40 = \$58,240$. This is assuming one bay of single diagonal bracing on each of the four faces. If two bays per face were used, the extra cost of the KISS Method would be about \$116,000.

The differences in size and cost between the KISS Method and the Uniform Force Method are apparent in Figure 19. From a scientific point of view, the reason the KISS Method gives a larger connection is due to inefficiency in force transmission. The beam to column connection (interface D)

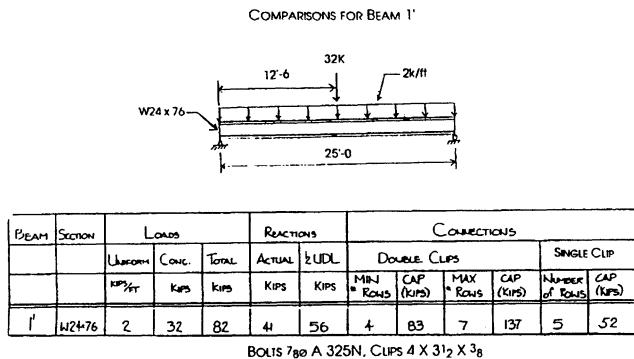

Fig. 11. Comparisons for beam 1 of Figure 8, uniform and concentrated loads.

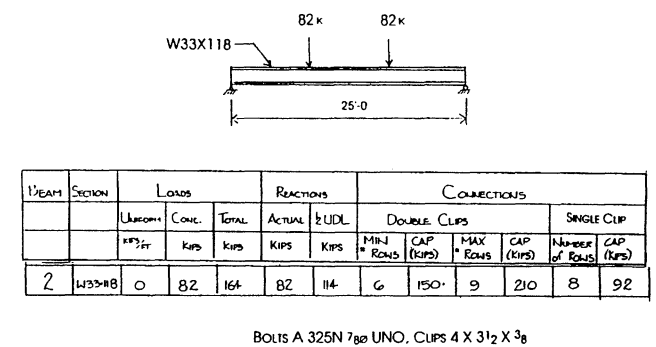

Fig. 12. Comparisons for beam 2 of Figure 8.

Table 3.
Comparison of Uniform Force Method Predicted with Test Results

Test Specimen	Predicted Results						Test Results		Test Capacity + Predicted Capacity
	Brace to Gusset A (kips)	Gusset to Beam B (kips)	Gusset to Column C (kips)	Beam to Column D (kips)	Predicted Capacity (kips)	Predicted Failure Interface	Test Capacity (kips)	Test Failure Interface	
Chakrabarti / Bjorhovde 30°	142 (3,5) ¹	184 (7)	216 (5)	152 (12)	142 (3,5)	A (3,5)	143	A (5)	1.01
Chakrabarti / Bjorhovde 45°	142 (3,5)	182 (7)	164 (5)	210 (12)	142 (3,5)	A (3,5)	148	A (5)	1.04
Chakrabarti / Bjorhovde 60°	142 (3,5)	169 (7)	155 (5)	342 (12)	142 (3,5)	A (3,5)	158	C (5)	1.11
Gross / Cheek No. 1	73 (4)	212 (7)	67 (12)	149 (9)	67 (12)	C (12)	116	A (4)	1.73
Gross / Cheek No. 2	78 (4)	77 (7)	143 (7)	NL ²	77 (7)	B (7)	138	A (4)	1.79
Gross / Cheek No. 3	84 (4)	94 (7)	171 (7)	NL ²	84 (4)	A (4)	125	A (5)	1.49

¹Limit state number from Table 1, typical

²NL = No Limit; this part of connection does not carry any of brace load P

is not used to carry any of the brace force. This is why the KISS Method gives such a small beam to column connection in Figure 19. To carry the load around this area, the large couples are required on the gusset edges. A simple way to judge efficiency of force transmission was given by Thornton (1992). It is a rough way to judge the “smoothness” of the load paths through the connection. The lower the efficiency number, the better the connection. For the Uniform Force Method, the efficiency of the connection of Figure 19 is 1.39 while that of the KISS Method is 1.97. These results are similar to the differences in cost. Thus, the technically better method for design also yields a cheaper design.

INFORMATION

The Uniform Force Method is probably the most efficient way to design bracing connections, but it must be supplemented by information about what are referred to as transfer forces or connection interface forces. These are sometimes obvious by application of the “art” of load paths, but not always. Also, the information given by the engineer can be wrong regarding transfer forces even if it is right regarding member forces.

Figure 20 shows a typical ambiguous situation. How much of the bracing forces to the left of the column are transferred

to the right of the column at Point A? This unspecified force is the “transfer force.”

Faced with this situation, the fabricator can perform analyses as shown in Figures 21 and 22 for assumed simultaneous and non-simultaneous loads. This results in possible transfer forces varying from 223k to 23k. Without further information from the engineer, the fabricator has no choice but to design for 223k, which will be safe but very expensive. The connection design strategy, based on ignorance, is shown in Figure 23!

This problem occurred on an actual job, and when the engineer realized our problem, told us the transfer force at Point A was 30k (Figure 24) and proceeded to provide the TF force at all ambiguous points on his drawings. Obviously, designing for 30 kips rather than 223 kips is much more economical as well as being safe. It is a design based on knowledge rather than ignorance.

For another example of an ambiguous situation, again consider Figure 4. This shows axial forces on the beams along with the engineer’s note:

“Design beam end connections for axial loads shown on plans.”

The framing plan shown is from an actual job and is not a

partial plan, that is, no other beams frame to it other than those shown. So there are certain points, such as point A, where designing for the axial force makes no sense because there is no place for the 90k load to go.

When the engineer was queried about this, he was annoyed and sent us a fax stating: "Design beam end connections for axial loads shown on plans." He repeated the note on his drawing and was basically saying, "Do what you are told, dumb fabricator!" We said, "OK, that means at Point B we design the beam to column connection for 20 kips, right?" He repeated his earlier fax. Now, at Point B, there happens to be a brace with 85 kips in it and the engineer provided the usual detail of a wrap-around gusset as shown in Figure 25. So we sent a copy of Figure 25 showing how his note would be interpreted in this case. When he saw this, he finally paid attention and said, no, he wanted 85 kips between the beam and column as shown in Figure 26. We agreed that was right, but that 90 kips at Point A was wrong. He agreed and changed his drawing to Figure 27, where the transfer forces are clear.

These two examples show that unclear transfer forces are sometimes uneconomical, as in the first example, but also can

be unsafe, as in the second example. To reinforce the point that the omission of transfer force data can lead to very serious design inadequacies is demonstrated in the next example. Figure 28 shows a partial elevation from an engineer's drawing. The notes on the drawings included one which is shown in Figure 28, i.e. "Design beam end connections for the axial loads shown." Now, the axial loads shown are obviously from the engineer's computerized frame analysis, design, and drawing production program. As such, they are member forces not connection interface or transfer forces. Consider point A. Here we are told to design the beam end connection (interface D of Figure 16) for the beam on the left for 160 kips, yet the opposing beam has only 20 kips as shown. What is happening at this point is that the brace force coming down the column is transferred directly to the beam through the gusset to beam connection (interface B of Figure 16) and never reaches the column. The beam to column connection should be designed for shear and 20 kips tension. Designing for 160 kips tension is expensive and wrong. Now consider Point B. Here the brace passes from the upper left to the lower right. There are no axial member forces shown on either

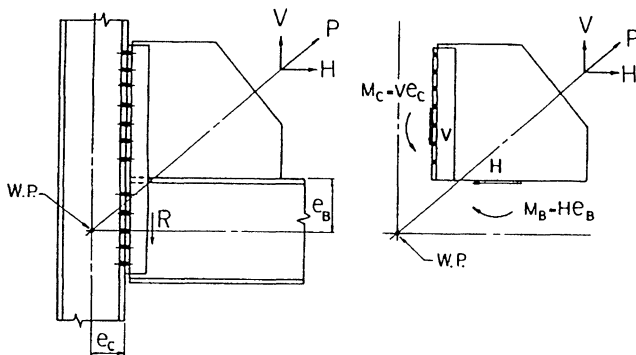

Fig. 13. The "KISS" method.

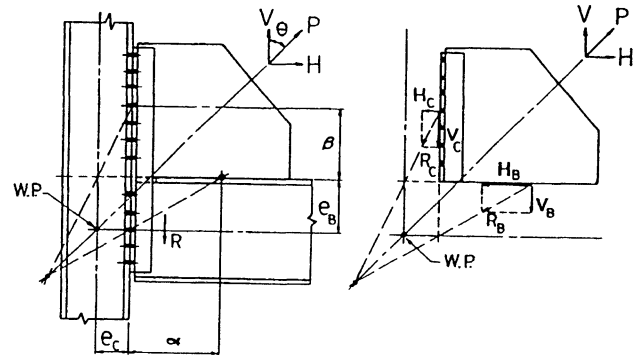

Fig. 15A. The uniform force method.

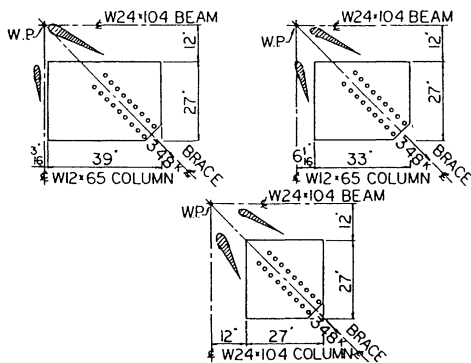

Fig. 14. Gusset edge force resultant envelopes 45° working point models (adapted from Richard, 1986).

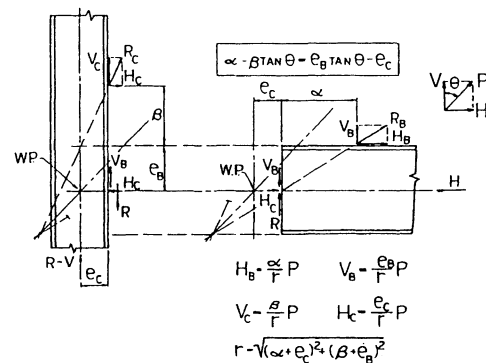

Fig. 15B. Force distributions for the uniform force method.

beam, because the computer indicated no axial forces for these beams. Therefore, the beam to column connections are designed for shear only. This is exactly what the detailer did in accordance with the above mentioned note, as seen in Figure 29 (shown opposite hand). But it is wrong. What is happening here is that the brace force must be transferred across the column from the left to right. The beam to column connections (interface D) of both beams must be matched and must carry the horizontal components of the brace forces. These are interface forces and not member forces. As such, they are calculated by no presently available computer software. The engineer was wrong to specify that beam end connections be designed for the member forces shown on the drawings. At point A this error causes the structure to be too expensive. At point B this error causes the structure to be grossly unsafe. The only way to avoid this problem is for the engineer to work out the transfer forces and present them on the drawings. This has been done for the frame of Figure 28 in Figure 30. The resulting correct detail for point B is shown in Figure 31 (opposite hand again).

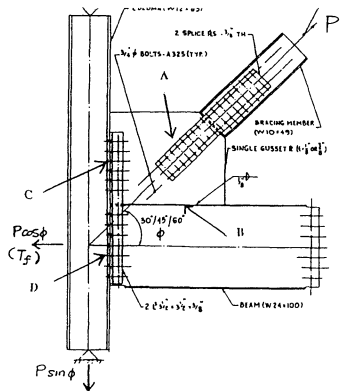

Fig. 16. Chakrabarti/Bjorhovde test specimen.

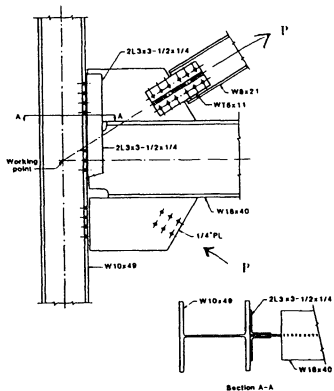

Fig. 17. Gross/Cheek test specimen no. 1.

Moment Connections

Like shear connections, moment connections are well understood. Here the problem is lack of information in the “released for construction” drawings which generally leads to expensive (but safe) connections, but the main problem is that member design should also have taken into consideration the design of the connections. If this is not done light weight columns will be chosen by the frame design software, but the constructed cost of the structure will be high because of the connections.

Columns, when part of an unbraced frame, are designed for bending moment as well as axial force. The designer uses a rigid frame analysis computer program, which also possibly does a code check using the beam column interaction equations or he performs the latter operation manually. What the designer generally does not consider in his column design is the “panel zone” between the column and the transverse framing beams and this can be a costly oversight.

Figure 32 shows a W14x90 column 34-ft. long with fillet welded stiffeners and a same cost W14x120 with no stiffeners. However, if a W14x99 column will work, a less expen-

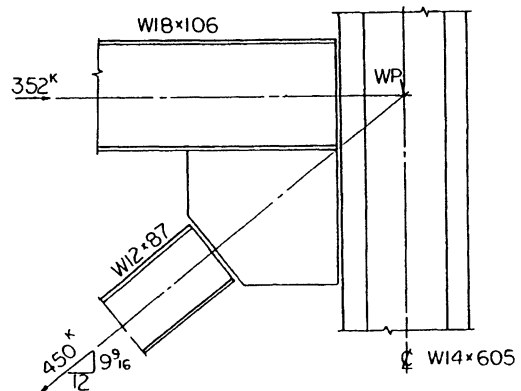

Fig. 18. Design example (see AISC 1992 and AISC 1994).

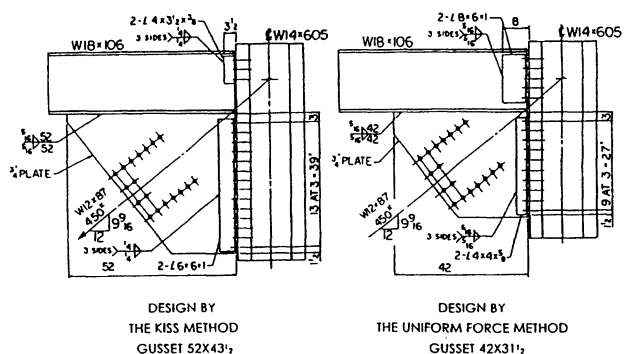

Fig. 19. Comparison of designs.

sive job will result. The W14×120 also may be less expensive if extra erection costs associated with beams framing to the weak axis of the W14×90 due to the stiffeners are considered. Figure 33 shows the same W14×90 column as Figure 32, but here the designer has specified full penetration groove welds of the stiffeners to the column. This almost triples the cost of the stiffeners and means that an unstiffened W14×176 will

cost about the same as the stiffened W14×90. Now, looking at the sections between W14×90 and W14×176, we see that we have available a W14×99, a W14×109, a W14×120, W14×132, W14×145, and a W14×159, all of which will yield a less expensive design if they satisfy the beam column design equations.

Figure 34 shows the “fabricator’s nightmare” of stiffeners

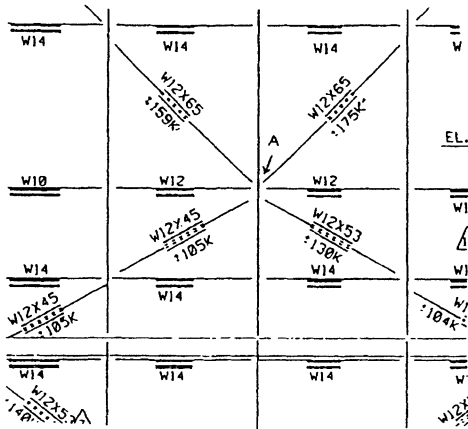

Fig. 20. Partial elevation—what is the transfer force at point A?

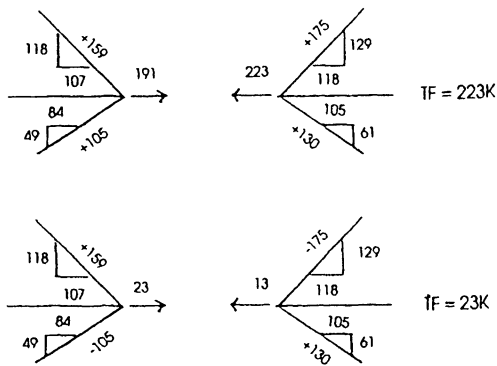

Fig. 21. Simultaneous loads—same load condition possible transfer forces.

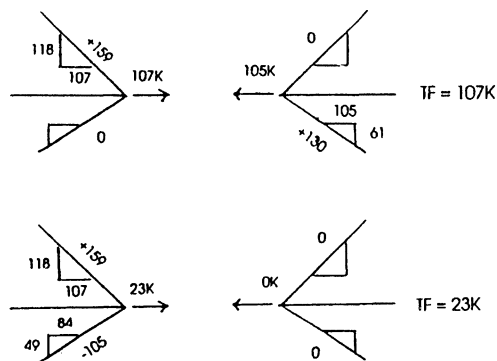

Fig. 22. Non-simultaneous loads—different load conditions possible transfer forces.

ASSUME THE WORST - HOPE FOR THE BEST!

WHEN IN DOUBT - MAKE IT STOUT!

USE "BELT AND SUSPENDERS"

Fig. 23. Connection design strategies based on ignorance.

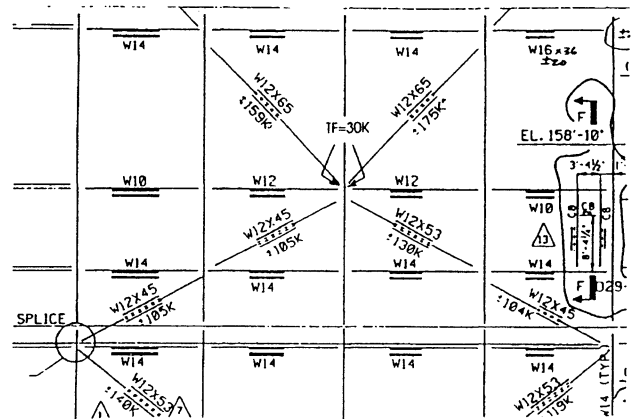

Fig. 24. Partial elevation transfer force is 30 kips per engineer.

ENGINEER'S NOTE: DESIGN BEAM END CONNECTIONS FOR AXIAL LOADS SHOWN ON PLANS

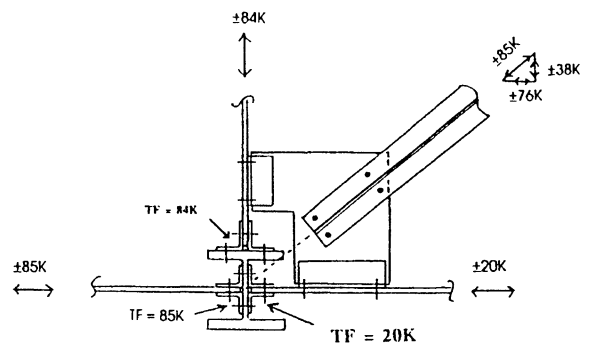

Fig. 25. Connection design forces based on engineers note.

REFERENCES

In addition to the specific references given below, much of this paper is abstracted from presentations given at the AISC National Steel Construction Conferences in 1991 and 1992, and subsequently published in *Modern Steel Construction* Magazine in the issues of February and June, 1992. The

material costs have been revised to reflect 1995 prices for this paper.

1. American Institute of Steel Construction, *Manual of Steel Construction, Vol. II, Connections*, ASD 9th Ed./LRFD 1st Ed., pp. 7-105-7-170.
2. American Institute of Steel Construction, 1994, *Manual of*

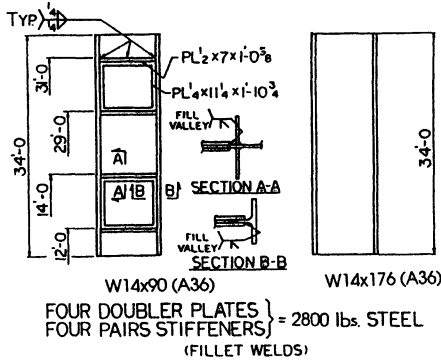

Fig. 34. Same cost columns—no transverse beams.

RULES OF THUMB

ONE PAIR STIFFENERS (FILLET WELDED)	=	300 lbs OF STEEL
ONE PAIR STIFFENERS (FULL PENETRATION WELDED)	=	800 lbs. OF STEEL
ONE PAIR DOUBLER PLATES	=	800 lbs. OF STEEL
ONE DOUBLER PLATE	=	400 lbs OF STEEL
ONE COLUMN SPLICE	=	500 lbs OF STEEL

Figure 35.

LENGTH OF COLUMN TRIBUTARY TO CONNECTION WITH STIFFENERS AND DOUBLERS	INCREASE IN WEIGHT PER FOOT WITH NO INCREASE IN COST OF 'CLEAN' COLUMN	
	STIFFENERS FILLET WELDED	STIFFENERS GROOVE WELDED
10	140	240
12	117	200
14	100	171
16	88	150
18	78	133
20	70	120

4 STIFFENERS
2 DOUBLERS
NO WEAK AXIS
BEAM CONNECTIONS

Fig. 36. Column selection design aid.

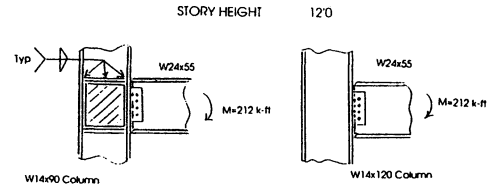

SINCE $120-90 = 30$ lbs < 117 lbs.
SAVED $117-30 = 87$ lbs/ft. X .20 \$/lb. = 17 \$/ft.
THEREFORE, PER 12' OF COLUMN
 $17 \times 12 = \$204$ SAVED
BUILDING WITH 1,000 LOCATIONS = \$204,000 SAVED

Fig. 37. Possible cost reduction with heavier clean columns.

DOUBLER PLATES COMMONLY SEEN REQUIREMENTS

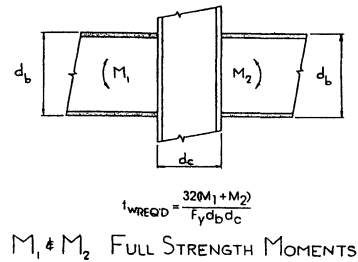

Fig. 38. Design for the full strength of the beams.

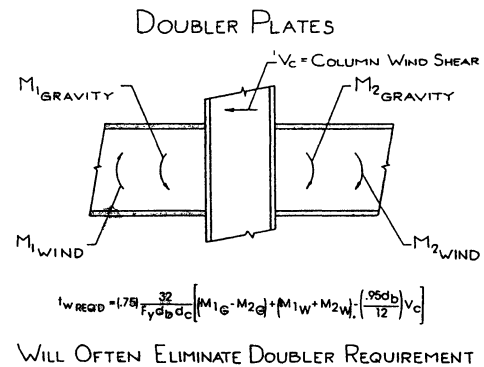

Fig. 39. Design for actual loads.

- Steel Construction, Vol. II, Connections*, LRFD 2nd Ed., pp. 11-17–11-48.
3. Bjorhovde, Reidar and Chakrabarti, S. K., "Tests of Full Size Gusset Plate Connections," *ASCE Journal of Structural Engineering*, Vol. 111, No. 3, March, 1985, pp. 667–684.
 4. Chakrabarti, Sekhar, K. and Bjorhovde, Reidar, *Tests of Gusset Plate Connections*, Department of Civil Engineering and Engineering Mechanics, University of Arizona, Tucson, 1983.
 5. Gross, John and Cheok Geraldine, "Experimental Study of Gusseted Connections for Laterally Braced Steel Buildings," *National Institute of Standards and Technology Report*, NISTIR 89-3849, Gaithersburg, MD, November, 1988.
 6. Gross, John L., "Experimental Study of Gusseted Connections," *AISC Engineering Journal*, 3rd Qtr., Vol. 7, 1990, pp. 89–97.
 7. Richard, Ralph M., "Analysis of Large Bracing Connection Designs for Heavy Construction," *Proceedings of the AISC National Engineering Conference*, Nashville, TN, June, 1986, pp. 31-1–31-24.
 8. Thornton, W. A., "On the Analysis and Design of Bracing Connections," *Proceedings of the AISC National Steel Construction Conference*, Washington, D.C., June, 1991, pp. 26-1–26-33.
 9. Thornton, W. A., "Design for Cost Efficient Fabrication and Construction," *Constructional Steel Design—An International Guide*, Edited by Dowling, Harding, and Bjorhovde, Elsevier Applied Science, London and New York, pp. 845–854.