

Plastic Design of Multi-Story Buildings—A Progress Report

JOSEPH A. YURA AND GEORGE C. DRISCOLL, JR.

This paper was presented at the AISC National Engineering Conference, Memphis, Tenn. in April, 1965.

AT THE AISC National Engineering Conference held in Omaha, Nebr., in May, 1964, the beginnings of Lehigh University's research on plastic design of multi-story frames were reported.¹ This paper is a progress report on work which has continued since that time.

The 1963 AISC Specification recommends plastic design for low buildings using ASTM A7 and A36 steels.² It also permits the use of plastic design for continuous beams in multi-story buildings which are fully braced against sway. Now research is underway in the Civil Engineering Department at Lehigh University to extend plastic design to buildings using high-strength steels and to all members in multi-story frames, whether they are braced or without bracing.

DESIGN OF BRACED MULTI-STORY FRAMES

The phase of the research on braced multi-story frames under the supervision of Dr. Le-Wu Lu is nearly completed. Satisfactory column solutions are now available to permit the complete plastic design of braced multi-story frames with confidence.

At the 1964 AISC Conference, comparisons of plastic and elastic designs of braced multi-story frames were shown. These indicated considerable savings of steel for plastic designs. At that time the plastic design was based on the load factor of 1.85 currently included in the AISC Specification. In view of the better column design knowledge available, further studies have been made considering the use of a load factor of 1.7. The load factor of 1.7 is currently used in many cases of plastic design. Many cases of allowable stress design by the 1963 AISC Specification actually have an inherent load factor of only 1.7 for structures which would now be required to have a factor of 1.85 if designed plastically. Figure 1 is a sketch of a three-bay ten-story frame recently designed as an illustrative example. A bar chart compares the

weights of steel in beams, columns, and total for the frame for the plastic design and for an allowable stress design. A weight savings of about 18 percent is shown to be possible by using plastic design.

A program of tests on full-size braced multi-story frames is currently underway. The purpose of these tests is to provide experimental data for comparison with plastic design methods. In this program the performance of connections and diagonal bracing is also studied. The test program considers four two-bay three-story braced frames. These are full size frames. In all cases the frame is the same. Only the loading condition varies for each test.

The loading conditions for the four tests are shown in Fig. 2. Uniform loads are shown for clarity; actual test loads are concentrated at the one-fourth points on the beams, and lateral loads are concentrated at each story level. A fixed-base condition is used for all the tests.

The loading condition shown in Fig. 2a represents full factored dead and full factored live loading on all the floors. The loads on the top story are 0.75 of the loads on the lower two floors in order to prevent the formation of

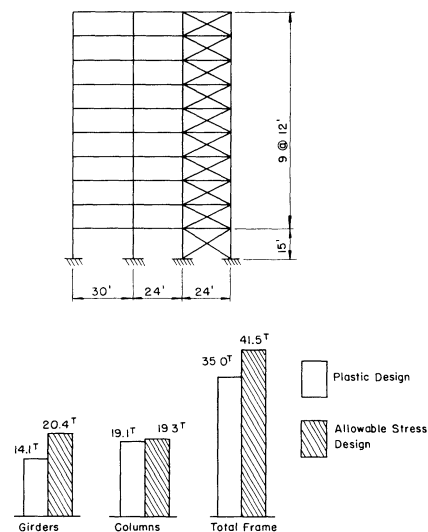

Fig. 1. Weight comparison for plastic design and allowable stress design

Joseph A. Yura is Research Instructor in Civil Engineering, Lehigh University, Bethlehem, Pa.

George C. Driscoll, Jr., is Research Professor of Civil Engineering and Chairman, Structural Metals Division, Fritz Engineering Laboratory, Lehigh University, Bethlehem, Pa.

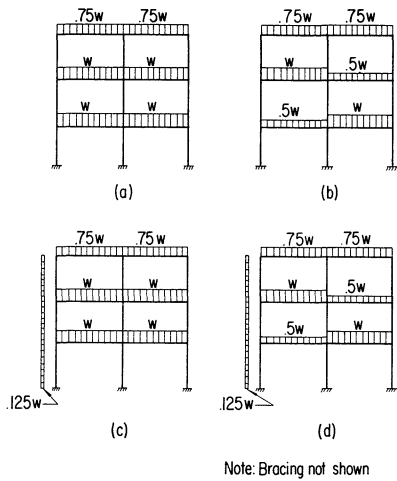

Fig. 2. Loading conditions for braced frame tests

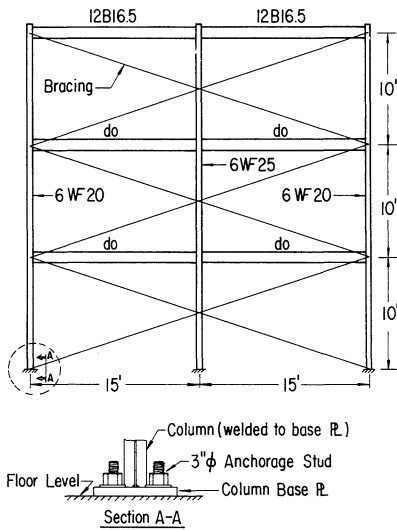

Fig. 3. Braced frame test specimen

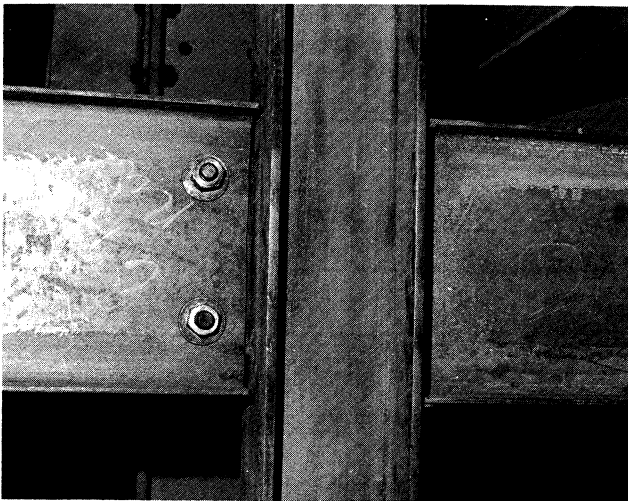

Fig. 4. Interior beam-to-column connection

a beam mechanism in the top story. A checkerboard loading arrangement is used in the second frame test as shown in Fig. 2b. The condition simulates full factored dead load on all the beams and full factored live load on alternate bays and floors. A uniform load approximately 0.5 of the ultimate load is applied first to all beams. Then, the additional loads to produce failure are applied on alternate bays and floors. Cases 2c and 2d are similar to the first two tests except for the addition of lateral load. These cases represent combined gravity and wind loading. They are used to study the effect of diagonal bracing in resisting lateral loads and the effect of lateral forces on the distribution of moments throughout the braced multi-story frame.

The test frame considered in the program is a rigid frame of continuous welded construction, shown in Fig. 3. A36 steel is used throughout. The columns are 15 ft center-to-center, 30 ft high and continuous from the top story to the bottom. The exterior columns are 6WF20, the interior column is 6WF25 and all beams are 12B16.5. The strong axis slenderness ratio of the columns is 45. These sections were chosen on the basis of realistic frame geometry and slenderness ratios.

The diagonal bracing was prestressed by means of a turnbuckle before the testing operation. The purpose of the prestressing was to offset slackening in the bracing due to column shortening under axial load. The prestressing operation permitted the measurement of the forces in the diagonal bracing.

The frame was shop fabricated in two large units, a one-bay three-story frame and an exterior column with the adjacent beams. The two units were spliced together at the interior column using a moment connection detail recommended in the *AISC Manual of Steel Construction*.² The interior beam-to-column connection is shown in Fig. 4. The splice consists of a web plate shop welded to the interior column. Erection bolts are used to align and support the beam. The beam flanges are welded to the interior column with full penetration butt welds, and the web of the beam is fillet welded around the shop-welded web plate. The plastic design of this interior connection did not require any stiffeners in the column.³

The exterior moment connection is shown in Fig. 5. The plastic design procedure required both flange stiffeners and diagonal stiffeners. If a counterclockwise moment is applied to the connection shown in Fig. 5 the diagonal stiffener is placed in tension. Through a fabrication error one frame had the diagonal stiffeners placed in both tension and compression. As a result exterior connections with tension stiffeners and compression stiffeners could be compared.

The fixed base detail is shown in Fig. 3. The column is welded to a 2½-in. base plate, and the base plate is prestressed to the foundation by means of two large anchor bolts.

In order to determine the forces in the bracing of the braced frame or the strength of an unbraced frame experimentally, the loading system must provide only negligible restraint to the frame. If large friction forces or restraining components exist in the loading system, the frame would be braced by the loading system itself. A test frame loaded directly by dead weight is an ideal system because the dead weight does not restrain the frame. The line of action of the gravity load remains vertical as shown in Fig. 6. However, gravity load is impractical due to space and load requirements. In the laboratory, hydraulic jacks are more practical. If the jack is fixed at one end as shown in Fig. 6, a restraining component is induced as the frame sways to the side.

A mechanism has been developed which eliminates the restraining component. It is called a *gravity-load simulator* because it approximates the behavior of actual dead weights. A schematic diagram of the mechanism to scale is shown in Fig. 7. It is composed of three rigid members, two inclined straight arms connected by a rigid triangular member. Hinges are located at both ends of the inclined arms, which makes the system stable only under upward loading. The triangular member permits one end of a tension jack to be connected at a certain point in space (load height) in reference to the fixed geometry of the mechanism (base width, top width and arm length).

For the type of mechanism shown, equilibrium requires that the line of action of the load pass through the instantaneous center, i.e., the point of intersection of the two arms. The position of the instantaneous center changes as the mechanism is deflected as shown in Fig. 7. The line of action of the load must also be vertical if it is to simulate gravity load. For every deflected position, the load height can be calculated which satisfies these two conditions, namely, that the load pass through the instan-

taneous center and that the load is vertical. Fortunately, the load height changes very little for various deflected positions. For engineering purposes it does not change at all for deflections up to 16 in. The simulator was designed for large deflections so that unbraced frames could also be tested.

Tests conducted on the gravity-load simulator show that for sidesway deflections up to 6 in. there is almost no measureable restraining component of the load. When the sidesway is 16 in., there is a horizontal component of only 400 lbs for a jack load of 80,000 lbs. Figure 8 shows the actual gravity-load simulator and the tension jack in a position corresponding to a sidesway of 16 in. The simulator is 11 ft wide at the base.

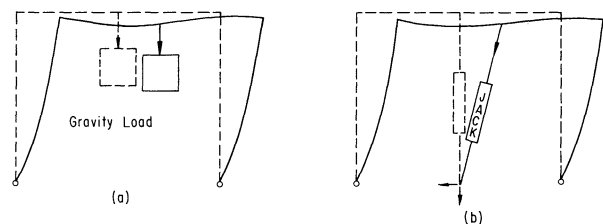

Fig. 6. Testing techniques for frames

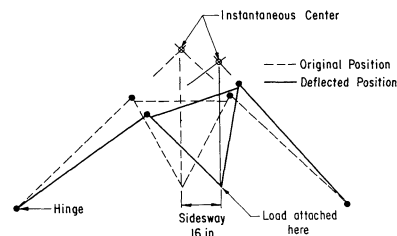

Fig. 7. Schematic of gravity-load simulator



Fig. 5. Exterior beam-to-column connection

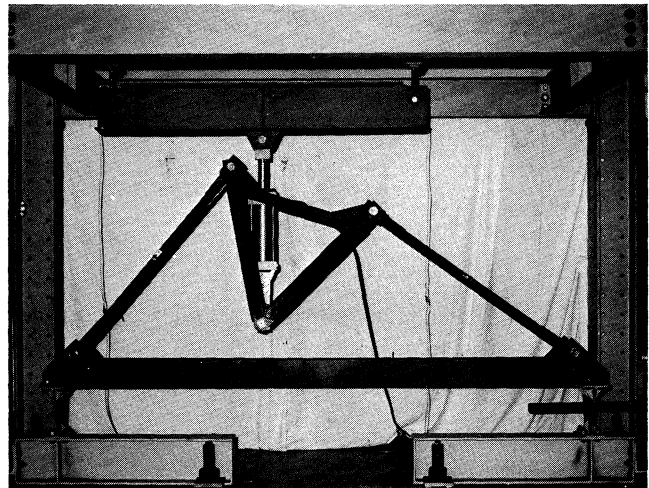

Fig. 8. Position of gravity-load simulator corresponding to 16 in. sidesway

The setup for testing the braced frames is shown in Figs. 9 and 10. A side view of the test setup is shown in Fig. 11. The test setup is similar in each bay and on every floor. A single frame is tested in each test setup. Vertical loads are applied to the *test frame* at the one-fourth points on the beams. Two equal concentrated loads are applied to the beams through calibrated *dynamometers* (to measure the load) attached to the *spreader beam* which divides the single load supplied by the hydraulic loading system. *Tension jacks* have one end attached to the spreader beam and the other end connected to a *gravity-load simulator*. The simulator is supported by the *loading frame* which is fixed to the foundation. Lateral loads are applied at each floor level by hydraulic jacks acting in tension as shown in Fig. 12. Movement of the test frame out of its plane is prevented by *lateral bracing* which is supported by the loading frame as shown in Fig. 13.

The lateral bracing should not be confused with the diagonal bracing which resists the unbalanced horizontal forces in the test frame. The lateral bracing consists of three rigid arms connected with ball-and-socket joints. It is a mechanism very similar to the gravity-load simulator except its geometry dictates a different property. It permits movement only in the plane of the web of the braced member. The advantage of this type of lateral bracing is that it remains effective without restraining the braced member from in-plane movement. Lateral bracing which is rigid would restrain the braced member when large deflections occur.

Loads are applied to the test frame by hydraulic cylinders acting in tension. Oil from a central supply is pumped to the jacks by an air pump. The oil is distrib-

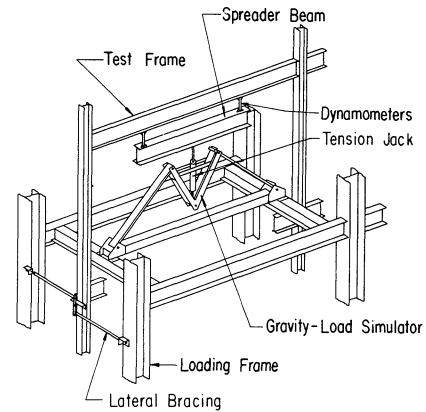

Fig. 10. Typical bay of test setup

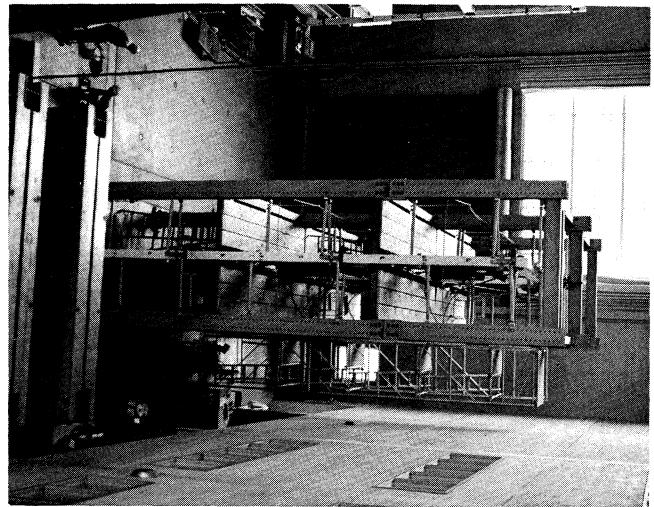

Fig. 11. Side view of test setup

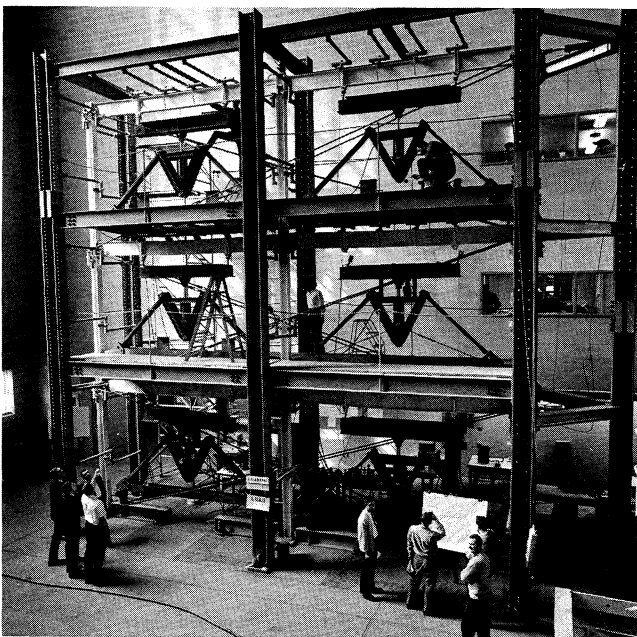

Fig. 9. Test setup for braced multi-story frames

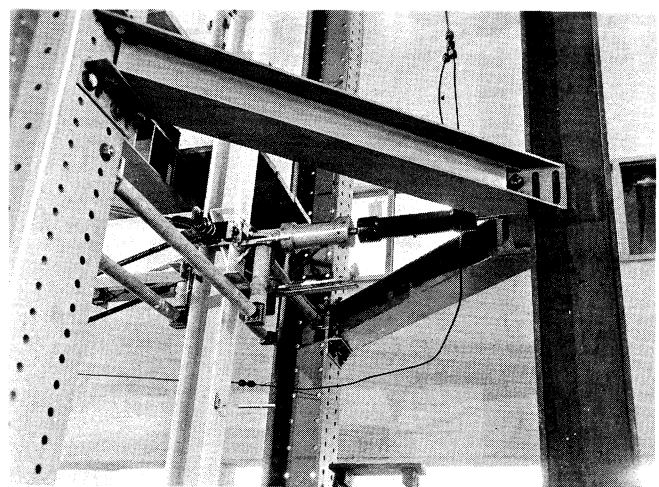

Fig. 12. Lateral loading system

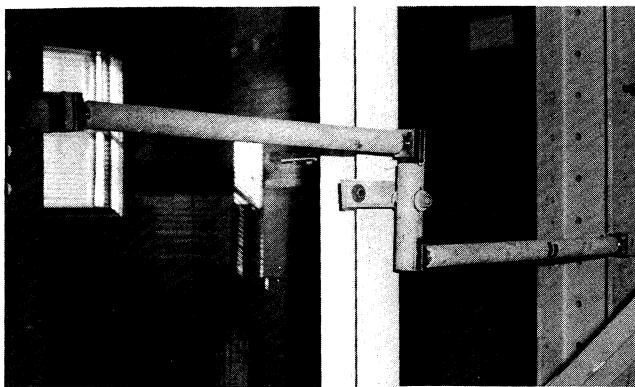

Fig. 13. Lateral bracing mechanism

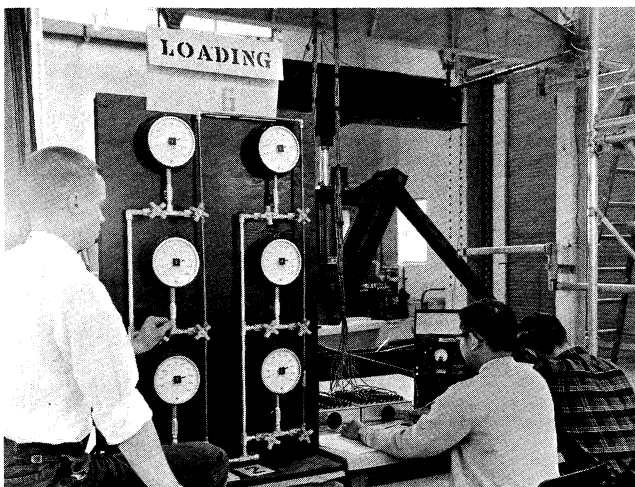

Fig. 14. Loading control console which distributes oil to the jacks

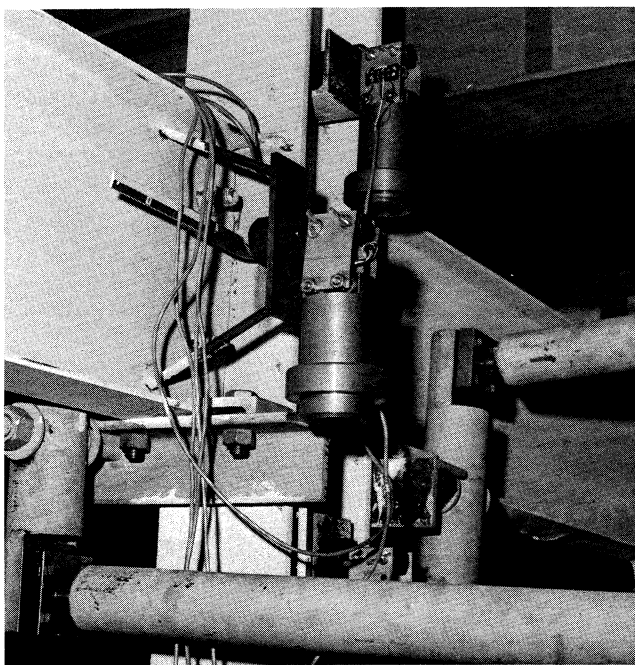

Fig. 15. Gages measure rotations at the joints

uted to the hydraulic jacks by the control console shown in Fig. 14, which permits a different load in each jack. A 5,000 psi gage measures the pressure in each line.

The rotations of all joints of the test frames were measured. The rotation gages shown in Fig. 15 consist of a heavy weight and a thin strip of spring steel. When the joint rotates, the heavy weight tends to assume a vertical position and bending moment is applied to the thin strip of steel. Strain gages on the steel are calibrated to read the rotations in terms of bending strain. Deflections at various points on the structure are measured by means of transits and levels sighting on scales.

Currently (June, 1965) three braced multi-story frame tests have been completed, Cases a, b and d in Fig. 2. The fourth test, the frame subjected to uniform vertical load and wind load, will be a demonstration in the Summer Conference on Plastic Design of Multi-story Frames at Lehigh University in August, 1965. Two of the tested specimens are shown in Fig. 16.

A load-deformation curve for the braced frame subjected to factored dead load on all the floors and factored live load on alternate bays and floors is shown in Fig. 17. The curve is typical of all the tests conducted. The predicted maximum load based on plastic methods of analysis is shown as a band of values to indicate the variation of material properties in the test frame. The maximum load attained compares very favorably with the predicted value.

The working load of 20.1 kips based on plastic design is shown in Fig. 17. The working load is calculated by

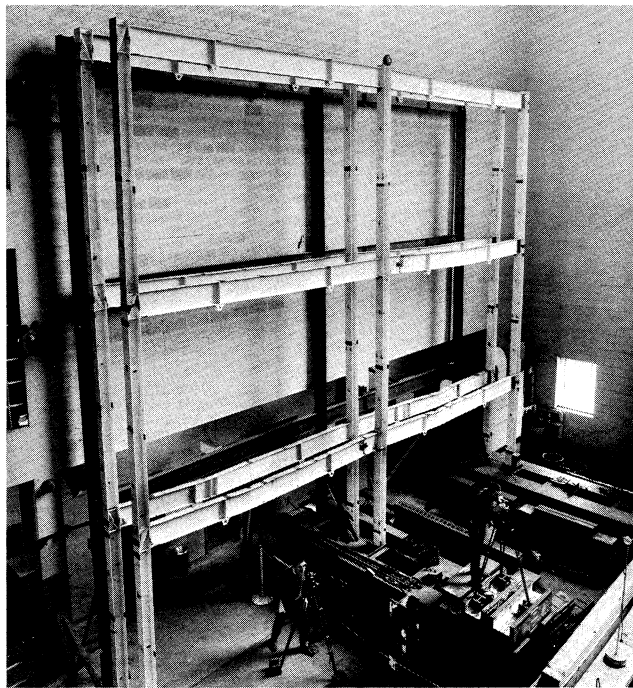

Fig. 16. Braced frames after testing

dividing the theoretical maximum load by a load factor of 1.7. The working load based on elastic analysis and allowable stress methods is 14.1 kips. The plastic method gives a higher permissible working load.

The first observed yielding in the test frame occurred in the lower floor beam at the interior column connection. The load at first yield is denoted by point a in Fig. 17. Point b denotes the load at which lateral buckling started in the lower floor beam and point c corresponds to local buckling at the midspan of this same beam. A mechanism in the lower floor beam occurred at the maximum load. The unloading of the structure was caused by the local buckling in the beam.

The locations where the plastic bending capacities of the cross sections were reached (plastic hinges) are shown in Fig. 18. The loads at which the various plastic hinges formed are also shown. The first hinges formed in the lower and upper floor beams at the interior beam-column connection. The structure, however, carried higher load until hinges formed in the roof beams. Hinges then formed under the load point in the lower floor beam and after further loading a hinge formed at location 4 which completes a mechanism in the beam. However, the load continued to increase slightly because strain-hardening occurred at the two hinges at the end of the beam. Under this increased load hinges formed in the exterior column and under the load point in the upper floor beam as denoted by location 5.

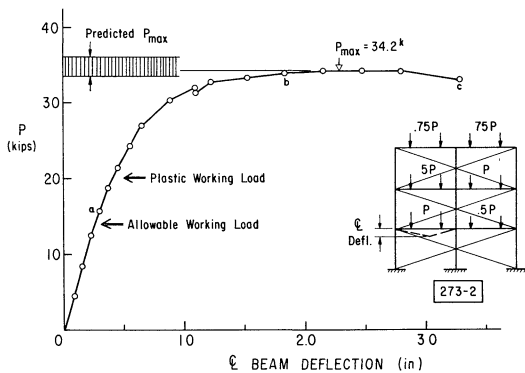

Fig. 17. Typical load-deformation curve for braced frame

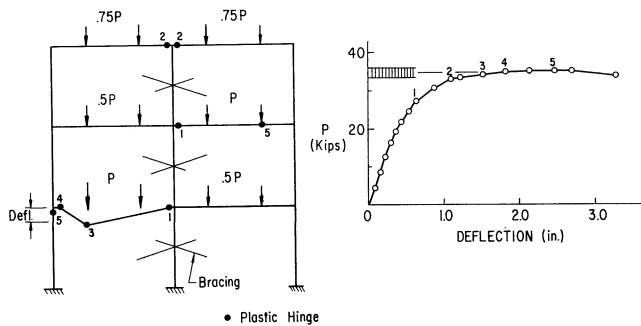

Fig. 18. Order of formation of plastic hinges

The load-deformation curves for the other two tests are very similar to the curve of Fig. 17. Plastic analysis also predicted the maximum load in these tests. For the test in which lateral loading was applied, the diagonal bracing carried all the lateral loading and the lateral load did not affect the distribution of the moments in the frame.

Typical elements from the tested frames are shown in Figs. 19 through 23. The elements shown indicate behavior corresponding to point c in Fig. 17. They do not represent behavior under working conditions. The test frame was whitewashed before testing so that flaking off of the mill scale from the steel would indicate yielding. Dark areas in the specimens indicate yielding.

Figure 19 shows a beam after a mechanism has formed. Plastic hinges have formed at the ends and near the center of the span. The midspan deflection is approximately two inches at the ultimate condition shown. The span is 15 ft. The central plastic hinge area is shown in Fig. 20. Local buckling has occurred at the hinge location. Lateral buckling of one of the beams in the test series is shown in Fig. 21. The beam was braced at the location of the labeling sign and at the unpainted area. The unbraced l/r_y was 35. The beam was forced to buckle between the braces, which indicates the lateral bracing was effective.

A typical interior connection after hinges have formed in each beam is shown in Fig. 22. The field splice is on the left. The connection behaved satisfactorily in that hinges were forced to form in the beams. Figure 23 shows an exterior connection in which the diagonal stiffener is in tension because the moment is applied in a counter-clockwise direction. (The area of the beam near the column is not whitewashed.) A hinge has formed at the end of the beam. There is rather mild yielding in the web of the column, and there is also minor yielding in the diagonal stiffener. There is no yielding in either one of

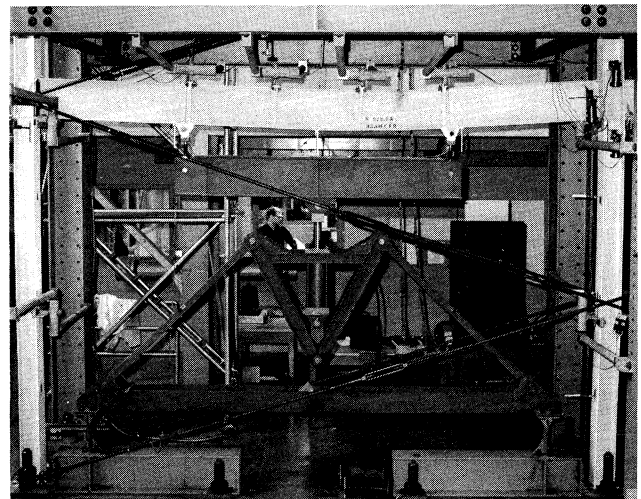

Fig. 19. Beam after a mechanism has formed

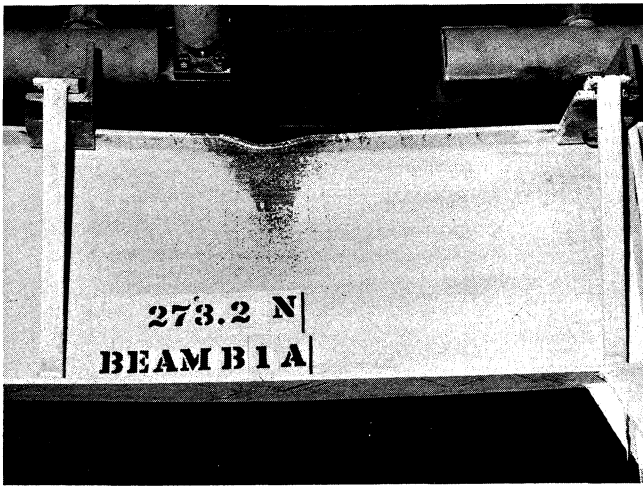

Fig. 20. Local buckling at plastic hinge location

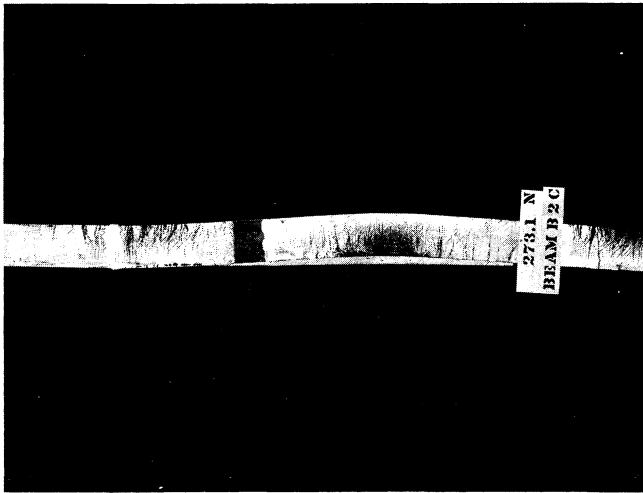

Fig. 21. Lateral buckling of a beam at ultimate load



Fig. 22. Interior beam-to-column connection with plastic hinge in both beams

the flange stiffeners. Figure 24 shows a similar connection in which a plastic hinge has also formed at the end of the beam. But in this case the diagonal stiffener was placed in compression and the yielding is more extensive. The diagonal stiffener is very highly yielded. The reason for the difference in yielding between the two connections in Figs. 23 and 24 is that axial load from the column above the connection applies compressive forces to the diagonal stiffener. Since this force is additive when the stiffener is orientated as shown in Fig. 24, the diagonal stiffener yields earlier and more extensively than the stiffener shown in Fig. 23.

The test program has shown that the strength of braced multi-story frames can be predicted by plastic design methods. Behavior of the frame can be closely approximated by plastic analysis and plastic methods for proportioning connections and diagonal bracing produce satisfactory behavior of these elements.^{3, 4}



Fig. 23. Exterior connection, diagonal stiffener in tension

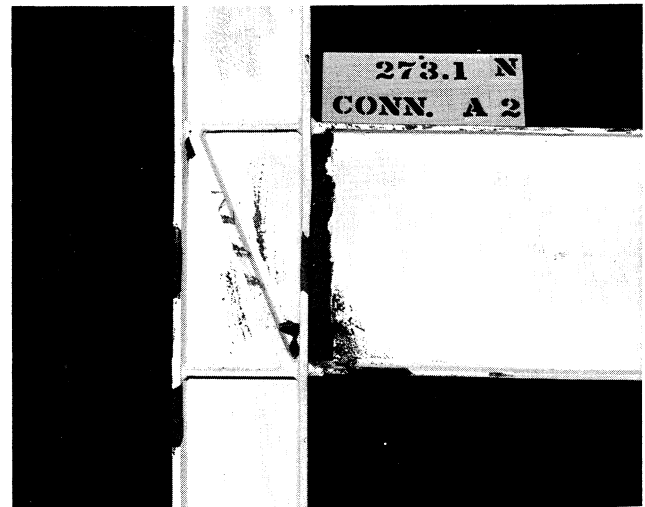

Fig. 24. Exterior connection, diagonal stiffener in compression

PLASTIC DESIGN IN HIGH-STRENGTH STEELS

Studies on plastic design in high-strength steels are being directed by Dr. Theodore V. Galambos. The objectives of these studies are to find if steels in the 50,000 psi yield point range can develop plastic hinges with sufficient rotation capacity to be suitable in plastic design and also to determine what proportions of members are needed to prevent local buckling and lateral buckling. Results so far have shown that members of ASTM A441 steel can develop plastic hinges when member proportions and lateral bracing are suitable.

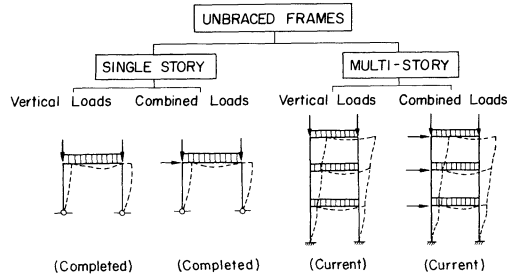

Fig. 25. Present status of unbraced frame studies

Table 1. Tentative Recommendations—Flange Local Buckling

Material	Proposed		AISC 1963
	Uniform Moment	Moment Gradient	
A36	$b = 18.5t$	$b = 17t$	$b = 17.5t$
A441	$b = 14t$	$b = 13.5t$	

Table 2. Tentative Recommendations—Bracing Spacing

Uniform Moment: ($1.0 \geq \rho \geq 0.7$)		
$\frac{KL}{r_y} = \sqrt{\frac{\pi^2 E}{\sigma_y \left(1 + \frac{0.56E}{E_{st}}\right)}} = \frac{226}{\sqrt{\sigma_y}}$		
Material	Proposed	AISC 1963
A36	$37 r_y$	$35 r_y$
A441	$31 r_y$	—
Moment gradient ($\rho < 0.7$)		
Material	Proposed	AISC 1963
A36	$70 r_y$	$(60-40 \rho)r_y > 35 r_y$
A441	$55 r_y$	—

It has been known that stouter sections must be used to take advantage of the higher strength available in A441 steel. Table 1 shows tentative recommendations for flange width-to-thickness ratios to prevent local flange buckling from reducing the bending strength of beams.⁵ Width-to-thickness ratios for two materials, A36 steel and A441 steel, are recommended for beams under uniform moment and for those in which there is moment gradient. A flange width 14 times the flange thickness is tentatively recommended for A441 beams with uniform moment, and a width 13.5 times the thickness is recommended for A441 beams with moment gradient. This is compared with a flange width 17.5 times the thickness as used with A36 steel in the 1963 AISC Specification. It may also be noted that a slight increase in width-to-thickness ratio to 18.5 for flanges of A36 steel can be recommended in the case of uniform moment but that the ratio should be dropped to 17 for flanges of A36 steel in regions of moment gradient.

Table 2 shows tentative recommendations for lateral bracing spacing for beams of A36 and A441 steels.⁵ First, a formula is given for the bracing spacing KL/r_y for members under uniform moment. By uniform moment is meant any beam in which the ratio of moments ρ at the two ends of a braced span is between 0.7 and 1.0. The formula is a function of the modulus of elasticity E , the strain-hardening modulus E_{st} , and the yield point stress σ_y . It can be simplified to $226/\sqrt{\sigma_y}$, where σ_y is given in ksi units. For A441 steel beams with uniform moment, the recommended bracing spacing is 31 times the radius of gyration about the y axis. A slight increase from $35r_y$ to $37r_y$ is also recommended for A36 steel. With moment gradient, the studies indicate that a bracing spacing of $70r_y$ would be suitable to replace the present bracing spacing formula for A36 steel, and that $55r_y$ might be used for A441 steel.

UNBRACED MULTI-STORY FRAMES

The final major phase of the current multi-story frame research at Lehigh University is the unbraced frame study which is also supervised by Dr. Le-Wu Lu. Figure 25 contains diagrams indicating the present status of the studies on unbraced frames. Work on single-story frames under both vertical and combined loads is completed. Two stability tests of unbraced three-story frames were completed in 1964 and discussed in Reference 1. Plans for three-story one- and two-bay frames to be subjected to combined vertical and horizontal loading are complete and fabrication of specimens is under way. Studies of methods for the plastic design of unbraced multi-story frames have reached the stage where it is possible to design some routine frames of modest size. Approximately two more years will be needed for completion of present studies.

SUMMER CONFERENCE ON PLASTIC DESIGN OF MULTI-STORY FRAMES

Enough of the research will have been completed by August, 1965, that it will be possible to present plastic design methods for some ordinary multi-story frames. Lectures on these methods will be presented by members of the Civil Engineering Department of Lehigh University at a conference on Plastic Design of Multi-story Frames to be held from August 24 to September 2, 1965. Demonstration tests supporting the theoretical solutions and design methods will be conducted in the Fritz Engineering Laboratory. A number of distinguished guests have accepted invitations to speak on subjects related to multi-story frames that do not fall within the areas of specialization of the Lehigh staff. A comprehensive set of lecture notes and design aids are being prepared for distribution at and after the conference.

SUMMARY

Progress during the past year on studies for extending the use of plastic design to multi-story frames and to structures using high-strength steels is reported.

“Braced” frames designed in examples have indicated that economies are possible in comparison with methods currently used. The possibility of using a load factor of 1.7 instead of the factor of 1.85 currently used in plastic design of rigid frames has been examined. Structures using this factor should exhibit the same safety against failure as that inherent in many structures currently designed by allowable stress design. Completed tests of three-story two-bay frames are discussed in support of new design procedures.

Design procedures for “unbraced” multi-story frames are being prepared and will soon be available for publica-

tion. Confirming tests of unbraced frames comparable to the completed tests on braced frames are being planned in the immediate future.

Results of studies on high-strength steels have given a tentative indication of the necessary bracing spacing and flange width-to-thickness ratios to assure that high-strength beams can be designed using concepts similar to those used for structural carbon steel beams.

A conference presenting details of plastic design methods for multi-story frames will be presented at Lehigh University in August, 1965.

ACKNOWLEDGMENT

The research reviewed in this paper is being conducted at Fritz Engineering Laboratory, Department of Civil Engineering, Lehigh University. Sponsorship for the program was provided by The American Institute of Steel Construction, the American Iron and Steel Institute, The Bureau of Ships, The Bureau of Yards and Docks, and the Welding Research Council. This support is gratefully acknowledged, as are the major contributions being made by members of the research project staff at Fritz Laboratory.

REFERENCES

1. *Driscoll, George C., Jr., and Beedle, Lynn S.* Research in Plastic Design of Multi-Story Frames, *AISC Engineering Journal*, Vol. 1, No. 3, July 1964, p. 92.
2. *Manual of Steel Construction*, Sixth Edition, *American Institute of Steel Construction, New York, N. Y., 1963.*
3. *Fisher, John W.* Welded Connections, p. 601, *Structural Steel Design*, ed. L. Tall, *Ronald Press, New York, 1964.*
4. *Levi, V.* Multi-Story Frames II, p. 736, *Structural Steel Design*, ed. L. Tall, *Ronald Press, New York, 1964.*
5. *Galambos, T. V.* “Beams,” Lecture Notes on Plastic Design of Multi-Story Frames (Chapter 3), *Lehigh University, 1965.*