

# Analysis of Helicoidal Girders

ASSAD ABDUL-BAKI AND DEAN BARTEL

HELICOIDAL GIRDERS are becoming very common structural members in staircases, bridges, and ramps. Their structural analysis is cumbersome and difficult, and is often simplified from the case of a curved space girder to the case of a circular bowed girder. A few investigators<sup>1-5</sup> have done some work on this problem, covering some special cases.

The purpose of this study is not only to present an analytical method of analysis, but also to provide the designer with a set of design charts from which he can determine directly the redundants of a fixed-ended helicoidal girder of any given symmetrical cross section, slope, and curvature. In spite of the fact that these charts are limited to the case of a uniformly distributed load, they cover a multitude of cases that include a wide range of geometrical configurations.

## DEFINITIONS AND GEOMETRY

Mathematically, a helix is defined as the shortest curve between two points on a cylinder. If a cylinder is cut vertically and expanded, the helix will project as an inclined line with a slope  $\alpha$  (Fig. 1b).

A helicoidal girder fixed at both ends represents an indeterminate structure of the sixth order. These redundants include three reactive forces,  $X_x$ ,  $X_y$  and  $X_z$ , and three reactive moments,  $X_r$  and  $X_p$  are bending moments, and  $X_t$  is the twisting moment (Fig. 1a). The reader is referred to the Appendix for the analytical solution of the redundants.

To define the position of a helicoidal girder, one needs to specify the following:

1. The radius,  $a$ , of the helix
2. The slope,  $\alpha$ , of the helix
3. The elevation  $h$  of end A of the helix, or the opening angle  $\theta_1$  of the helix projection on a horizontal plane (Fig. 1). Note that

$$\theta_1 = \frac{180}{\pi} \frac{h}{a \tan \alpha} \quad (1)$$

*A. Abdul-Baki is Assistant Professor of Civil Engineering, University of Missouri, Columbia, Mo.*

*Dean Bartel is Research Graduate Assistant, University of Missouri, Columbia, Mo.*

Since the geometry is always chosen by the designer, the remaining step is to select a section that satisfies the governing requirements of safety, aesthetics, economy, and clearance.

Once a symmetrical cross-section is chosen, its moments of inertia  $I_N$  and  $I_B$  and its torsional constant  $J$  can be determined. Note that  $I_N$  is the moment of inertia of the section with respect to the neutral axis in the direction of vector  $\mathbf{N}$ , and  $I_B$  is the moment of inertia of the section with respect to the neutral axis in the direction of vector  $\mathbf{B}$  (see Fig. 2). For the calculation of the torsional constant  $J$ , the reader is referred to any book on advanced strength of materials<sup>6,7</sup> or theory of elasticity.<sup>8,9</sup>

In order to provide a versatile set of design charts for the redundants, two parameters  $K_1$  and  $K_2$  are introduced, where

$$K_1 = \frac{GJ}{EI_N} \quad (2)$$

and

$$K_2 = \frac{I_B}{I_N} \quad (3)$$

The values of  $K_1$ ,  $K_2$ , and  $\alpha$  are varied independently over a large range, thus covering most practical cases.

In order to use the appended design charts, one needs to know the following:  $\alpha$ ,  $\theta_1$ ,  $K_1$  and  $K_2$ . The values for  $X_1$  to  $X_6$  can be substituted into the following expressions to give the redundants at end B:

$$\begin{aligned} X_x &= -waX_1 \\ X_y &= waX_2 \\ X_z &= waX_3 \\ X_p &= wa^2X_4 \\ X_r &= -wa^2X_5 \\ X_t &= wa^2X_6 \end{aligned} \quad (4)$$

In Eqs. (4),  $w$  is the intensity of the uniform load in force per unit length, and the positive directions of the redundants are taken according to the directions shown at point B in Fig. 1a. It is important to note that the appended charts and Eqs. (4) are only applicable if  $w$  is acting along the longitudinal axis of the girder.



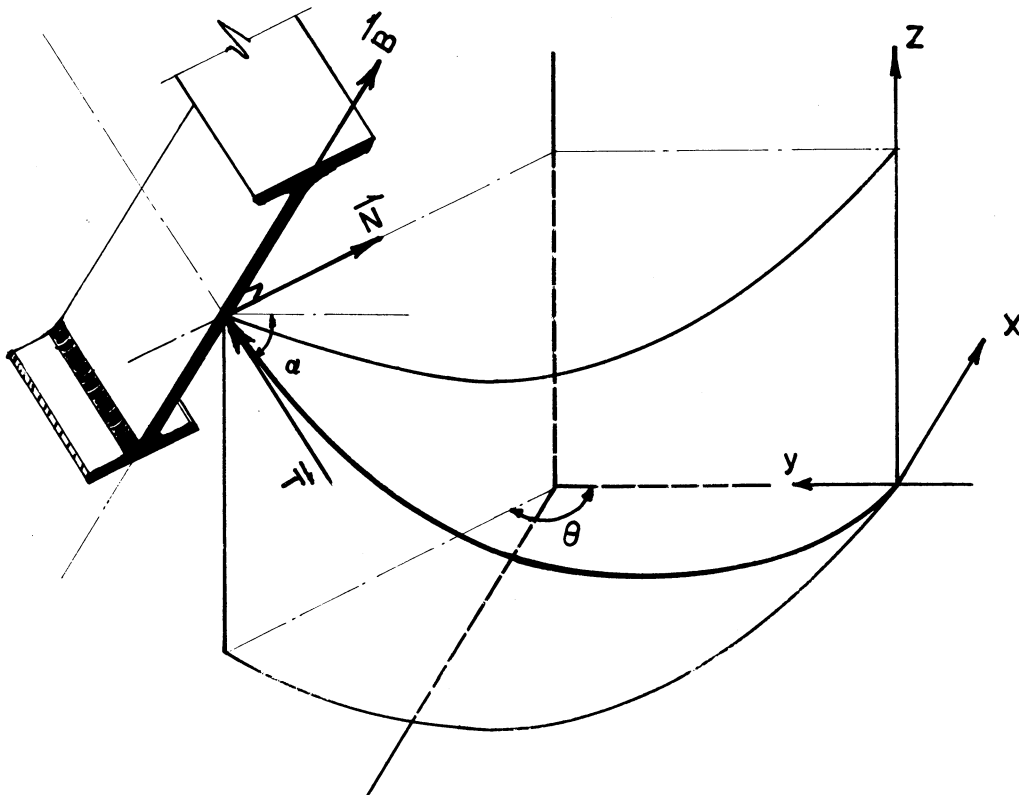

Fig. 2. Isometric cross section of a helicoidal girder showing the axes around which bending and torsion occur

If the load is eccentric and it is acting along a helix of radius  $a_1$  the expressions of  $r_{CD}$  and  $\mathbf{W}$  (Eq. A12, Appendix) should be modified only by replacing  $a_1$  for  $a$ , while maintaining unchanged all other expressions. A similar mathematical approach should be carried out to solve for the redundants. Because of the limitation of printing space, the authors have limited the design charts to the case of a uniform load acting along the center line of the girder.

#### NUMERICAL EXAMPLE

Given:  $\alpha = 25^\circ$ ,  $\theta_1 = 150^\circ$ ,  $a = 20$  ft, 12W190 and  $w = 0.5$  kips/ft. The moments of inertia for the 12W190 beam are:  $I_N = 1892.5$  in.<sup>4</sup> and  $I_B = 589.7$  in.<sup>4</sup>

Solution: The coefficient of torsion  $J$  can be determined by using the following expression<sup>10</sup>

$$\begin{aligned}
 J &= 1.1 \times \frac{1}{3}(\Sigma bh^3) \\
 &= 1.1 \times \frac{1}{3}[2 \times 12.67 \times (1.736)^3 + 10.91 \times (1.06)^3] \\
 &= 53.2 \text{ in.}^4
 \end{aligned}$$

where  $h$  is the thickness or the smallest dimension of each portion of the cross-section.

The values of  $K_1$  and  $K_2$  can be obtained now by using Eqs. (2) and (3), thus:

$$K_1 = \frac{12 \times 53.2}{30 \times 1892.5} = 0.01123$$

and

$$K_2 = \frac{589.7}{1892.5} = 0.31$$

Since the values of  $K_1$  and  $K_2$  do not fall exactly in any of the cases presented for  $\alpha = 25^\circ$ , one needs to do some interpolation. It was found that:

$$\begin{array}{lll}
 X_1 = 0.135 & X_2 = -0.037 & X_3 = 1.309 \\
 X_4 = 0.135 & X_5 = 0.615 & X_6 = 0.203
 \end{array}$$

The magnitudes of the redundants at end B can be determined from Eqs. (4), thus:

$$\begin{aligned}
 X_x &= -0.5 \times 20 \times 0.135 = -1.35 \text{ kips} \\
 X_y &= 0.5 \times 20 \times (-0.037) = -0.37 \text{ kips} \\
 X_z &= 0.5 \times 20 \times 1.309 = 13.09 \text{ kips} \\
 X_p &= 0.5 \times (20)^2 \times 0.135 = 27.0 \text{ kip-ft} \\
 X_r &= -0.5 \times (20)^2 \times 0.615 = -123 \text{ kip-ft} \\
 X_t &= 0.5 \times (20)^2 \times 0.203 = 40.6 \text{ kip-ft}
 \end{aligned}$$

However, if one considers this space helicoidal girder as a bowed girder (i.e.,  $\alpha = 0$ ), the values obtained for  $X_1$  to  $X_6$  are:

$$\begin{array}{lll}
 X_1 = X_2 = X_4 = 0 & & \\
 X_3 = 1.309 & X_5 = 0.693 & X_6 = 0.163
 \end{array}$$

The magnitudes of the redundants are, therefore:

$$\begin{aligned} X_x &= X_y = X_p = 0 \\ X_z &= 0.5 \times 20 \times 1.309 = 13.09 \text{ kips} \\ X_r &= -0.5 \times (20)^2 \times 0.693 = -138.6 \text{ kip-ft} \\ X_t &= 0.5 \times (20)^2 \times 0.163 = 32.6 \text{ kip-ft} \end{aligned}$$

Comparing the results of these two problems, one can conclude that the approximation of a helicoidal girder by a bowed circular girder is neither accurate nor justifiable in most cases.

### CONCLUSION

It is not simple to draw a general conclusion about the effect of  $K_1$ ,  $K_2$  and  $\alpha$  on the redundants because of the inconsistent trends of the redundant curves when  $\theta_1$  varies. However, one can state that  $X_1$ ,  $X_2$  and  $X_4$  will increase in general with respect to  $K_2$  when  $\theta_1$  is maintained constant, whereas  $X_3$  is independent of  $K_1$ ,  $K_2$  and  $\alpha$ , and varies linearly with respect to  $\theta_1$ .

The authors believe that any approximation of a helicoidal girder by a bowed girder should be used with caution. No general and specific conclusion can be drawn from the charts because of the large number of variables.

In spite of the fact that the charts presented are limited to the case of a uniform load acting along the longitudinal axis of the helicoidal girder, the method presented in the Appendix can be easily modified to take into account concentrated loads or eccentric uniform loads.

### APPENDIX

Let the coordinate system be chosen as shown in Fig. 1. The position vector of point C is presented as follows:

$$\mathbf{R} = -\hat{i}a \sin \theta - \hat{j}a \cos \theta + \hat{k}a \theta \tan \alpha \quad (\text{A1a})$$

where  $a$  is the radius of the cylinder.

$$\text{Let} \quad p = a \tan \alpha \quad (\text{A2})$$

$$\text{Then} \quad \mathbf{R} = -\hat{i}a \sin \theta - \hat{j}a \cos \theta + \hat{k}p\theta \quad (\text{A1b})$$

$$\text{and} \quad (ds)^2 = d\mathbf{R} \cdot d\mathbf{R} = \frac{a^2}{\cos^2 \alpha} (d\theta)^2 \quad (\text{A3})$$

$$\text{Thus} \quad \frac{d\theta}{ds} = \frac{\cos \alpha}{a} \quad (\text{A4})$$

The tangent vector  $\mathbf{T}$  to the space curve is

$$\begin{aligned} \mathbf{T} &= \frac{d\mathbf{R}}{ds} = \frac{d\mathbf{R}}{d\theta} \frac{d\theta}{ds} \\ &= (-\hat{i}a \cos \theta + \hat{j}a \sin \theta + \hat{k}p) \frac{\cos \alpha}{a} \quad (\text{A5}) \end{aligned}$$

Note that  $\mathbf{T}$  is a unit vector.

$$\begin{aligned} \mathbf{R}'' &= \frac{d\mathbf{T}}{ds} = \frac{d\mathbf{T}}{d\theta} \frac{d\theta}{ds} \\ &= (\hat{i}a \sin \theta + \hat{j}a \cos \theta) \frac{\cos^2 \alpha}{a^2} \quad (\text{A6}) \end{aligned}$$

and

$$\begin{aligned} \mathbf{R}''' &= \frac{d\mathbf{R}''}{ds} = \frac{d\mathbf{R}''}{d\theta} \frac{d\theta}{ds} \\ &= (\hat{i}a \cos \theta - \hat{j}a \sin \theta) \frac{\cos^3 \alpha}{a^3} \quad (\text{A7}) \end{aligned}$$

The curvature  $\mathcal{C}$  can be expressed as follows:

$$\mathcal{C}^2 = \mathbf{R}'' \cdot \mathbf{R}'' = \frac{\cos^4 \alpha}{a^2}$$

$$\text{Thus} \quad \mathcal{C} = \frac{\cos^2 \alpha}{a} \quad (\text{A8})$$

The osculating plane can be defined by the vectors  $\mathbf{T}$  and  $\mathbf{N}$ , where the latter is a unit vector perpendicular to  $\mathbf{T}$  and defined as follows:

$$\mathbf{N} = \frac{1}{\mathcal{C}} \frac{d\mathbf{T}}{ds} = \hat{i} \sin \theta + \hat{j} \cos \theta \quad (\text{A9})$$

A third unit vector  $\mathbf{B}$ , defined by  $\mathbf{B} = \mathbf{N} \times \mathbf{T}$ , forms with  $\mathbf{T}$  and  $\mathbf{N}$  a right-handed set of orthogonal unit vectors. Vector  $\mathbf{B}$  is called the binormal, and is shown in Fig. 1. Thus,

$$\mathbf{B} = \hat{i} \sin \alpha \cos \theta - \hat{j} \sin \alpha \sin \theta + \hat{k} \cos \alpha \quad (\text{A10})$$

Let the position vector  $\mathbf{R}_{CB}$  be expressed as follows:

$$\mathbf{R}_{CB} = \hat{i}a \sin \theta - \hat{j}a(1 - \cos \theta) - \hat{k}p\theta \quad (\text{A11})$$

If a uniform load is considered on the helicoidal girder, the position vector from point C to the centroid of the helicoidal sector is

$$\begin{aligned} \mathbf{R}_{CD} &= \hat{i}a \left[ \sin \theta - \frac{1}{\theta} (1 - \cos \theta) \right] + \\ &\quad \hat{j}a \left( \cos \theta - \frac{\sin \theta}{\theta} \right) - \hat{k}p \frac{\theta}{2} \quad (\text{A12}) \end{aligned}$$

and the load vector is:  $\mathbf{W} = -wa\theta\hat{k}$ .

The expressions of the moments in the directions of the three unit vectors are written without elaboration:

$$\begin{aligned} M_T &= \mathbf{T} \cdot \mathbf{r}_{CB} \times (\mathbf{X}_x + \mathbf{X}_y + \mathbf{X}_z) + \mathbf{T} \cdot (\mathbf{X}_p + \\ &\quad \mathbf{X}_r + \mathbf{X}_t) + \mathbf{T} \cdot \mathbf{r}_{CD} \times \mathbf{W} \\ &= a \sin \alpha [1 - \cos \theta - \theta \sin \theta] X_x + \\ &\quad a \sin \alpha [\sin \theta - \theta \cos \theta] X_y + \\ &\quad a \cos \alpha (\cos \theta - 1) X_z + (\sin \alpha) X_p - \\ &\quad (\cos \alpha \sin \theta) X_r - (\cos \alpha \cos \theta) X_t + \\ &\quad wa^2 \cos \alpha (\theta - \sin \theta) \quad (\text{A13}) \end{aligned}$$



DESIGN CHARTS

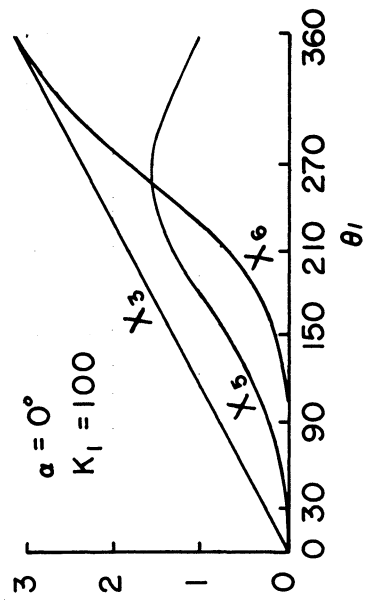
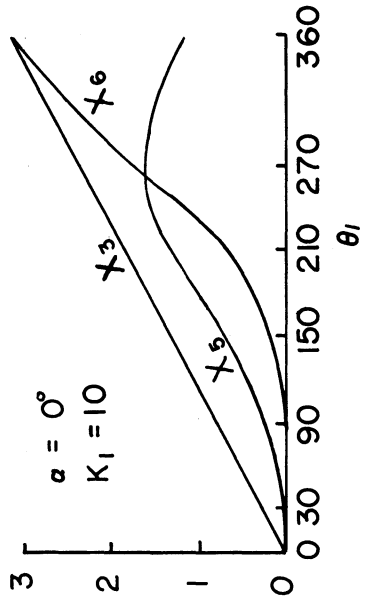
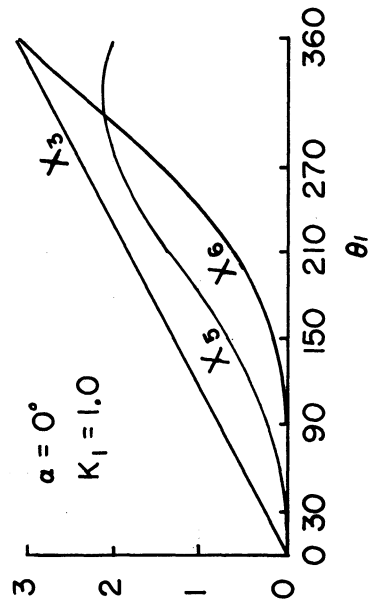
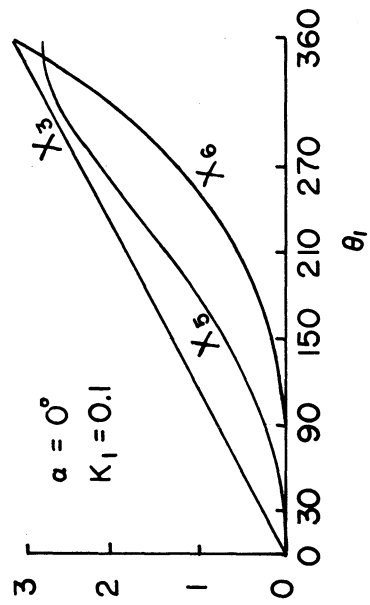

DESIGN CHARTS (CONT'D)

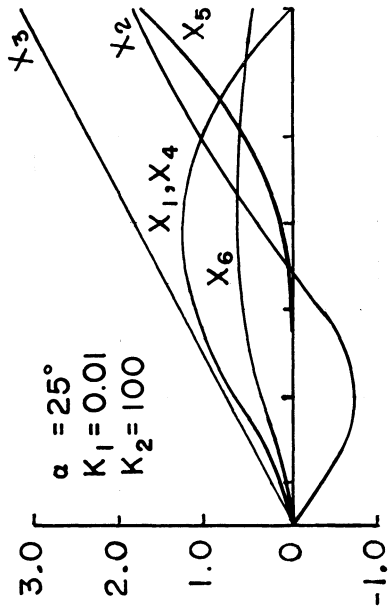
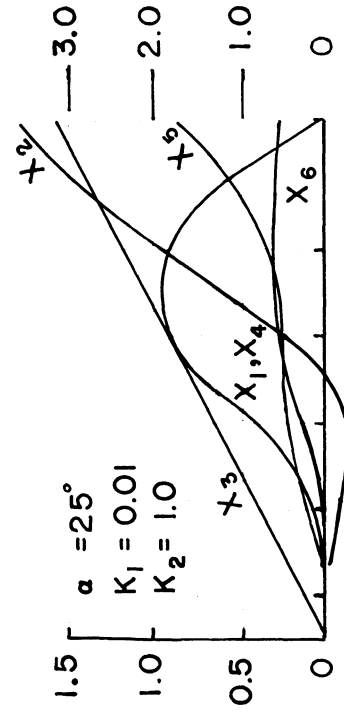
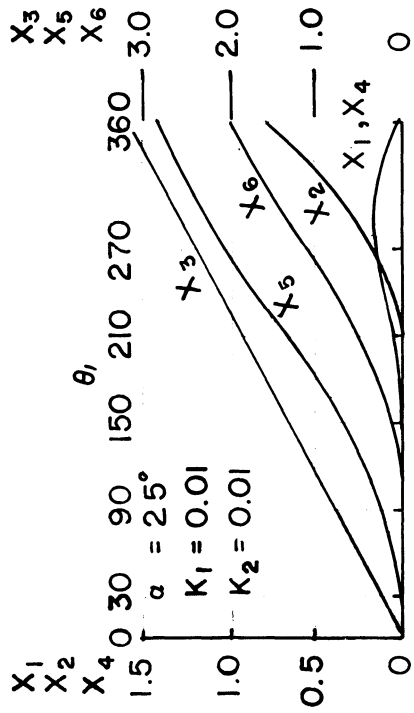
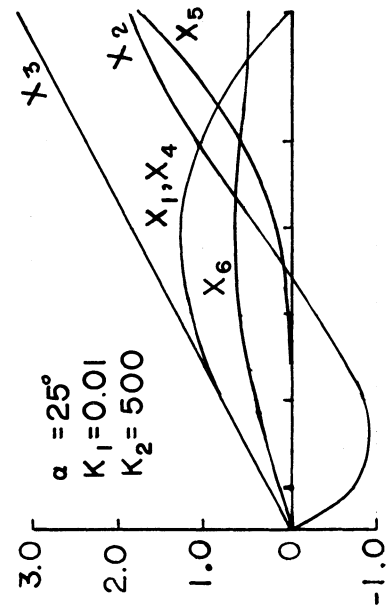
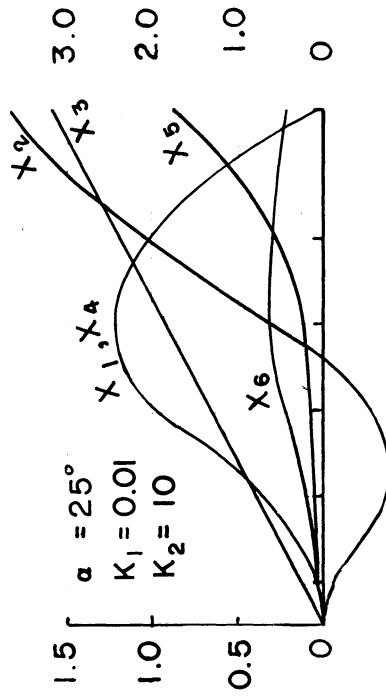
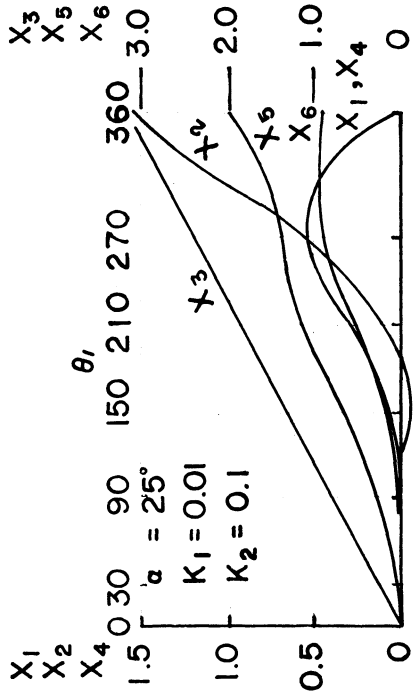

DESIGN CHARTS (CONT'D)

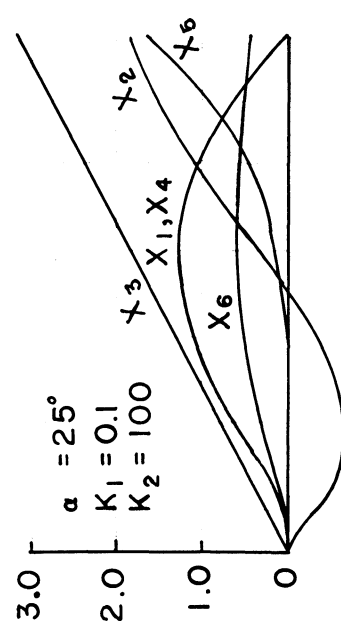
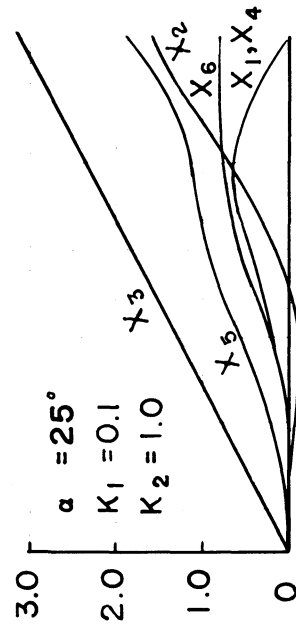
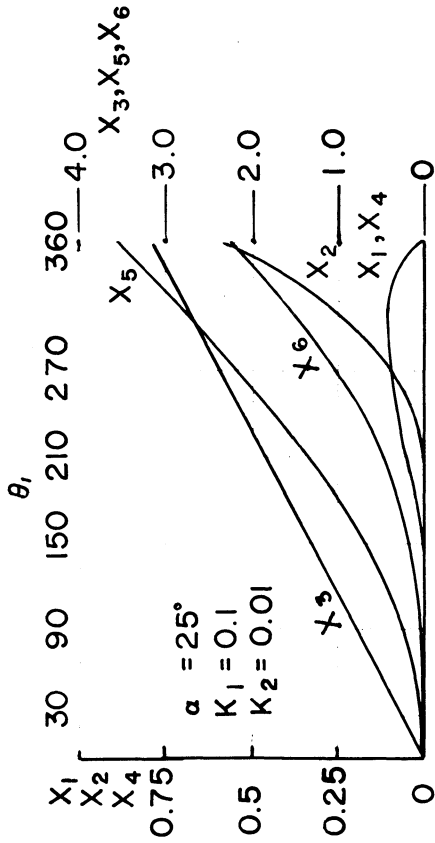
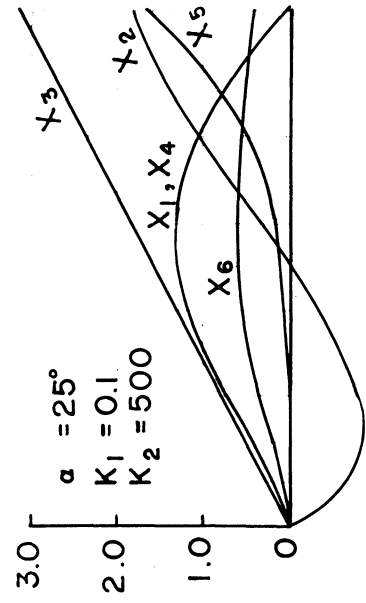
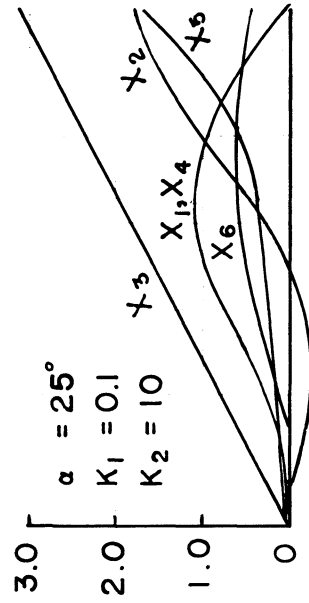
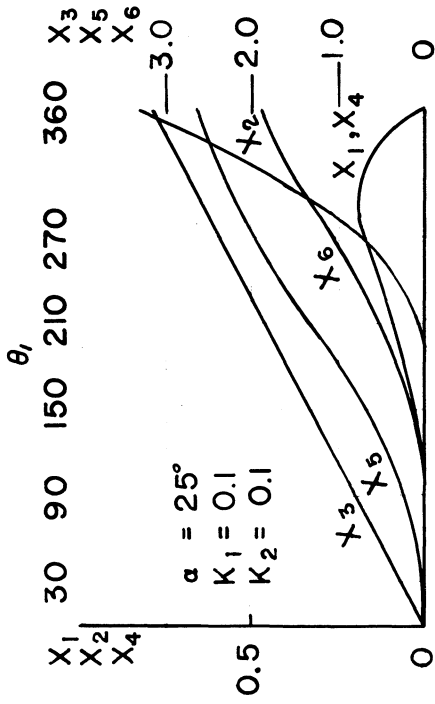

DESIGN CHARTS (CONT'D)

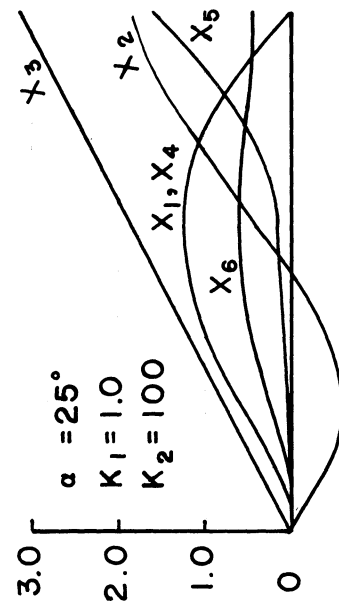
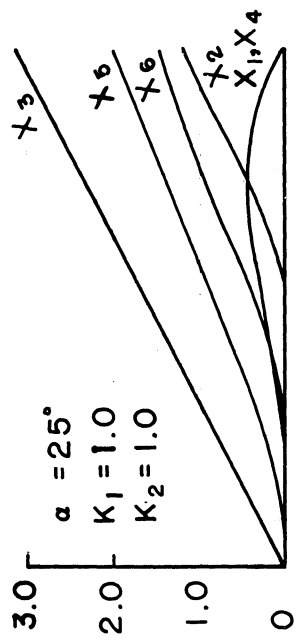
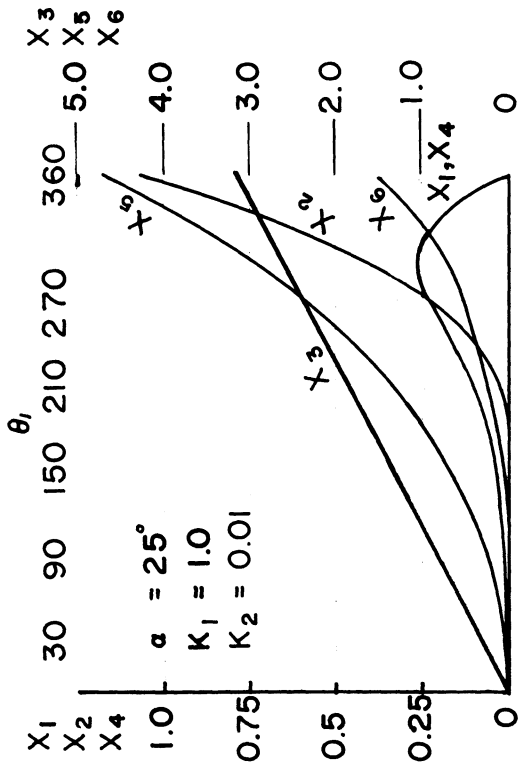
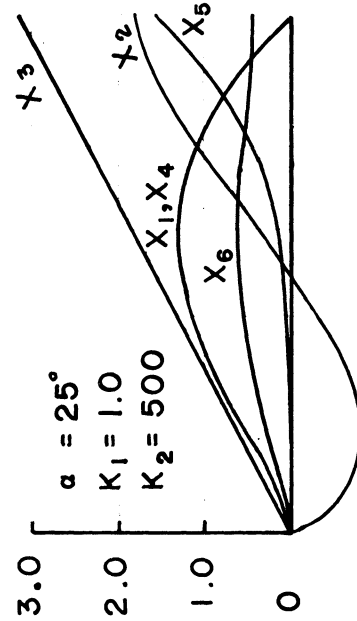
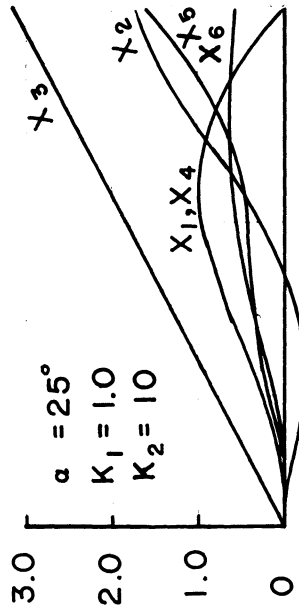
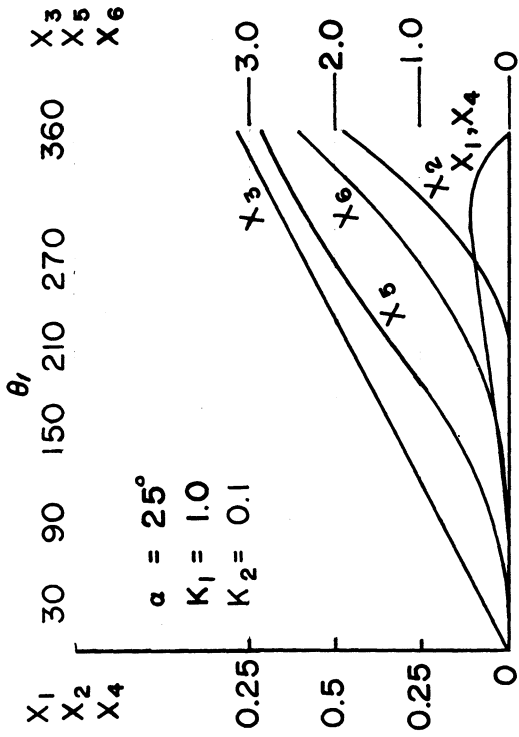

DESIGN CHARTS (CONT'D)

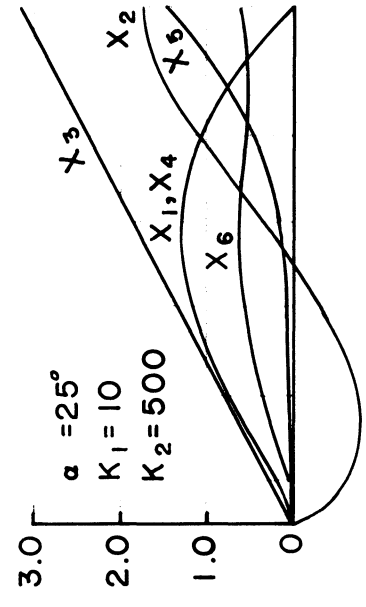
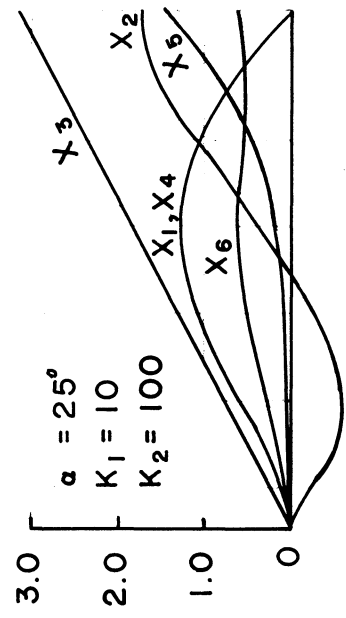
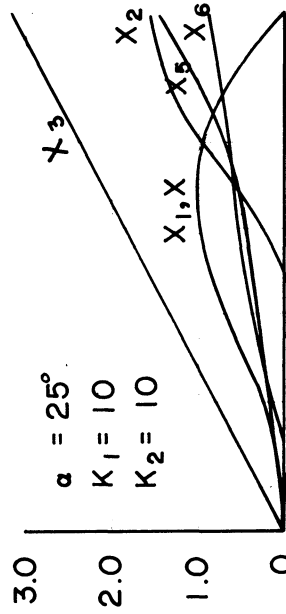
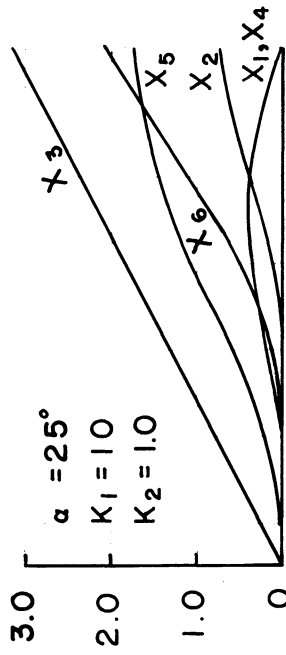
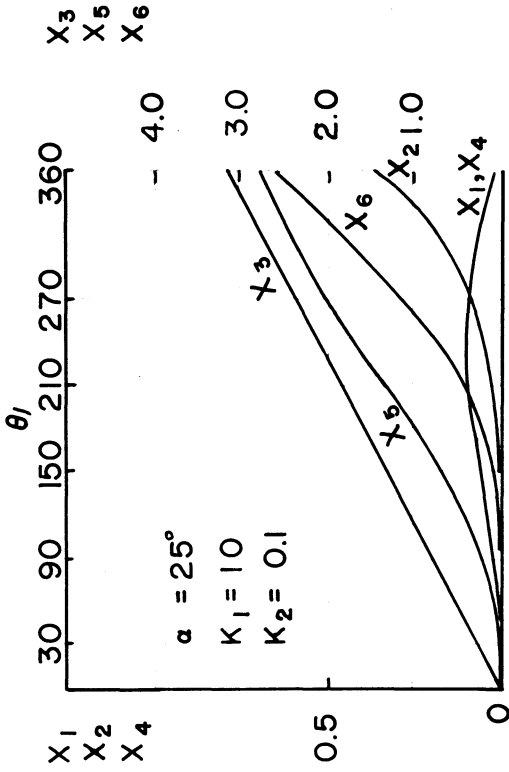
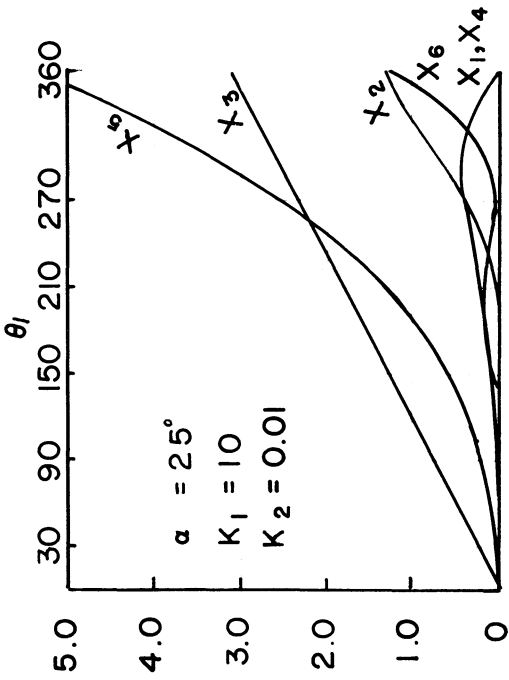

DESIGN CHARTS (CONT'D)

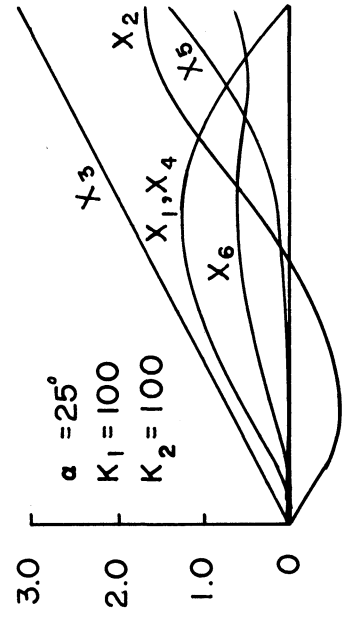
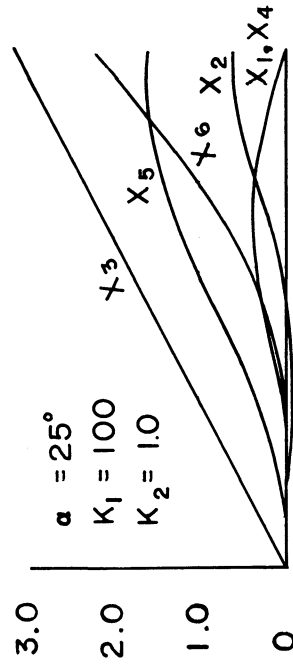
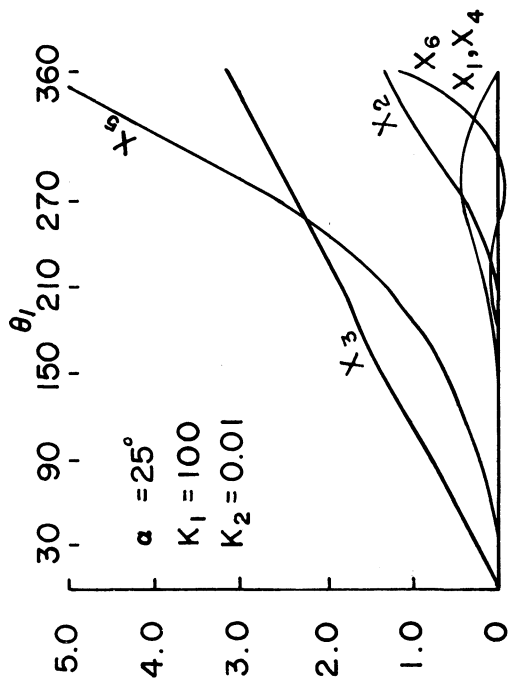
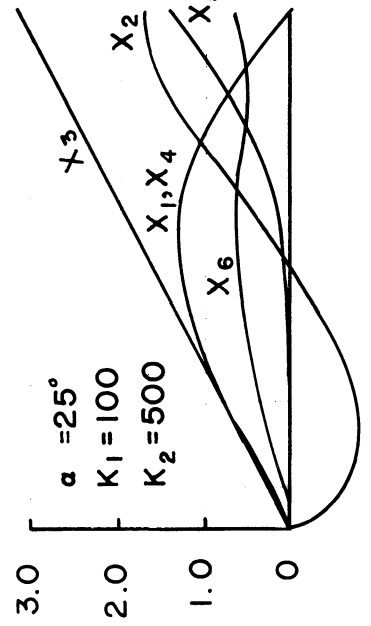
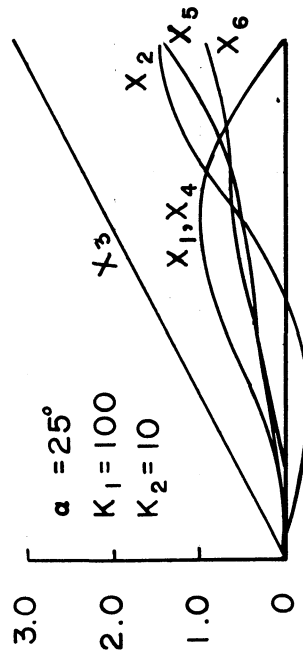
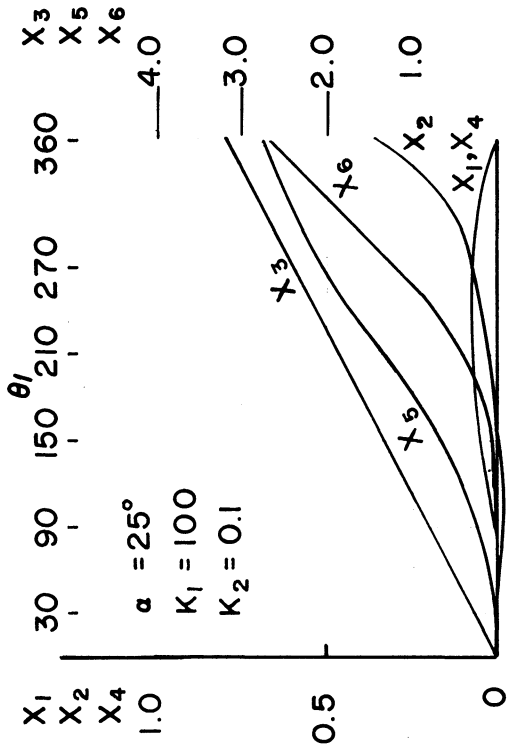

DESIGN CHARTS (CONT'D)

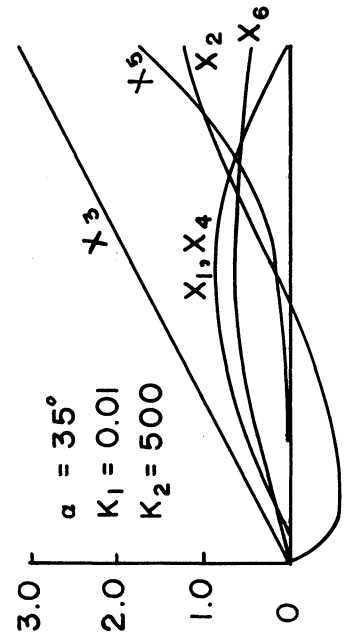
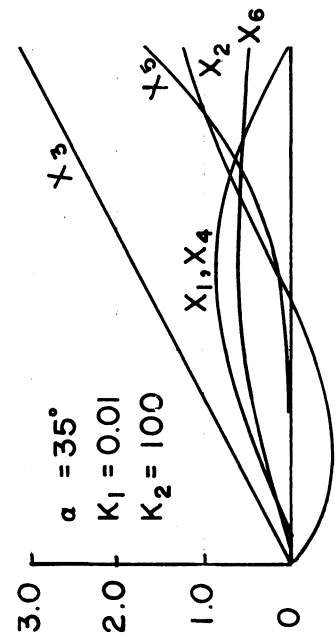
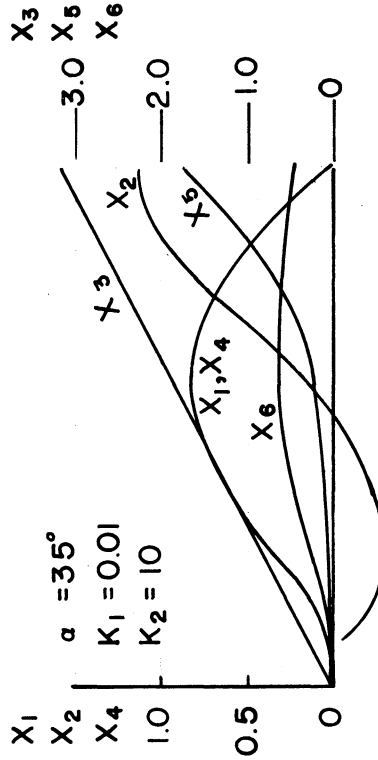
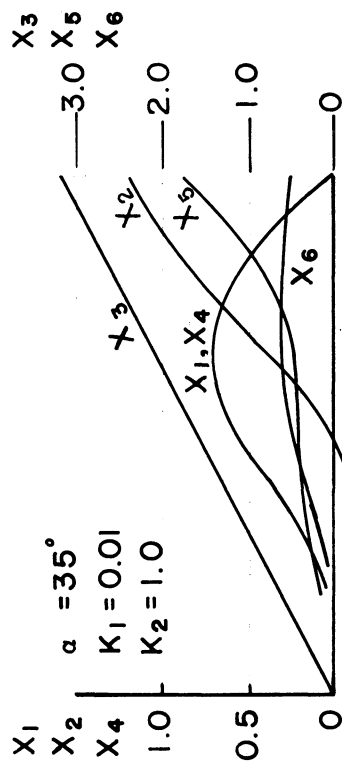
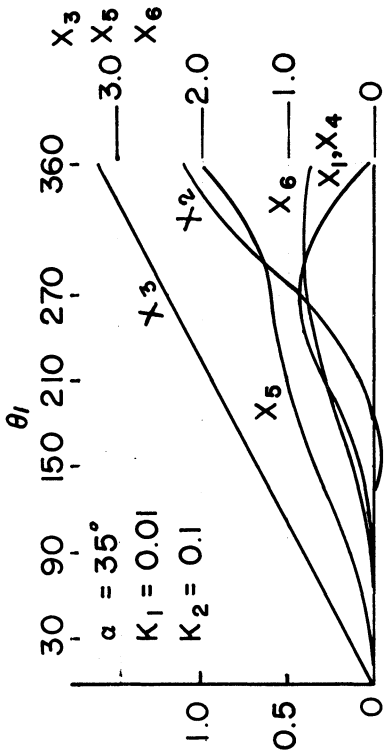
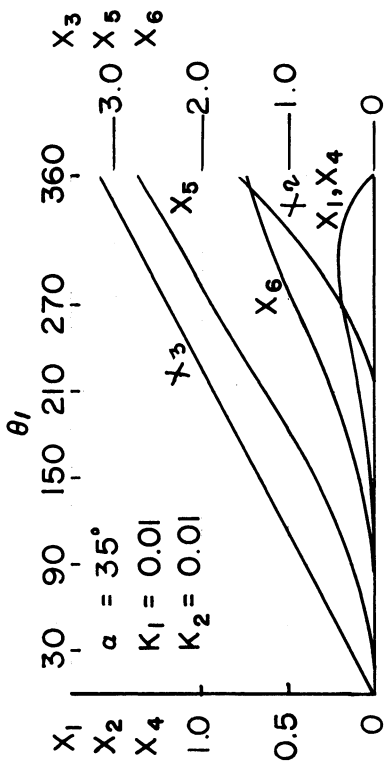

DESIGN CHARTS (CONT'D)

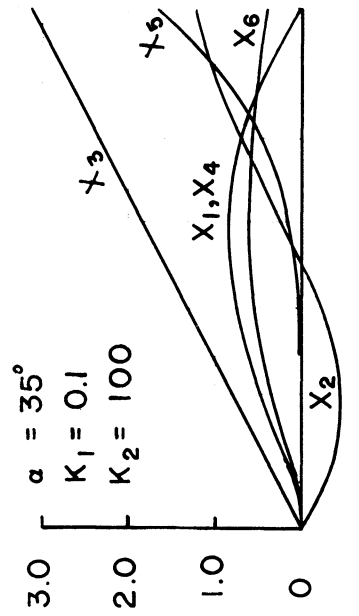
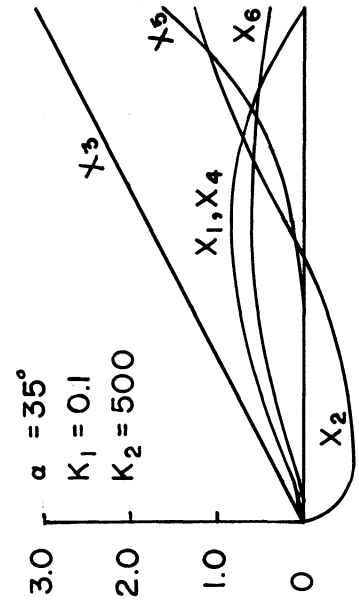
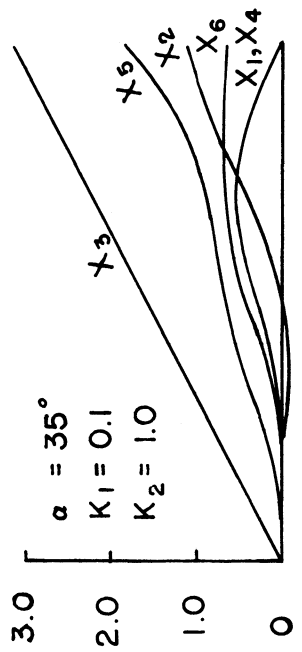
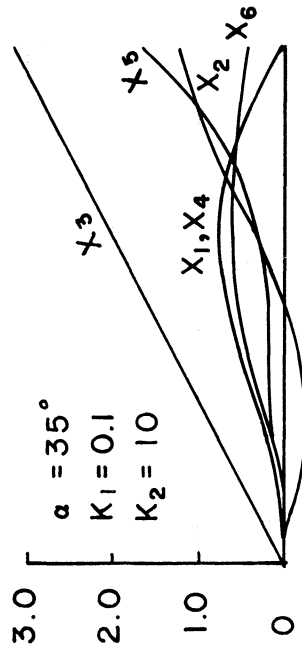
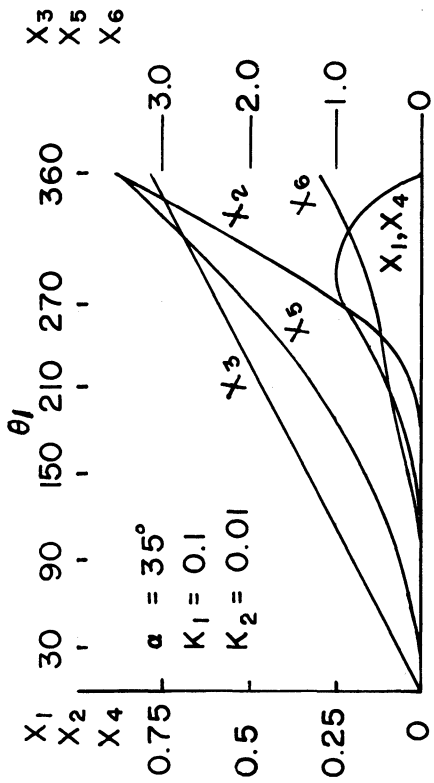
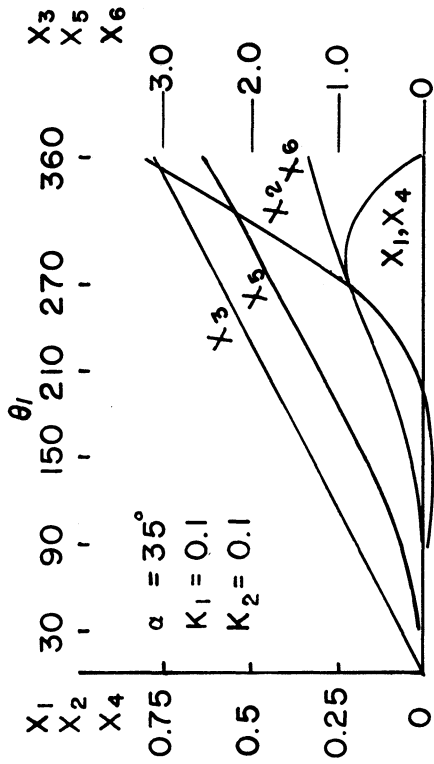

DESIGN CHARTS (CONT'D)

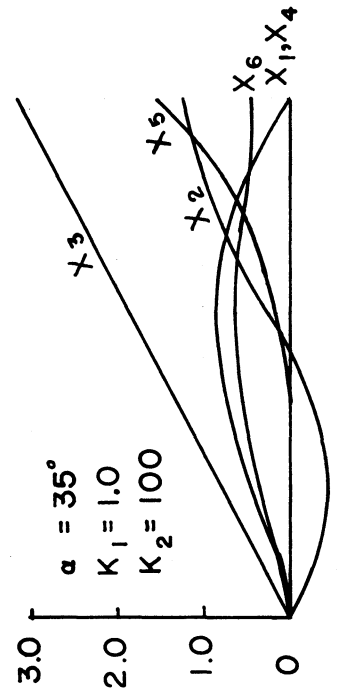
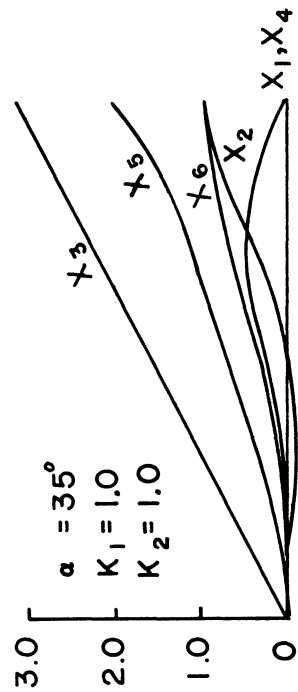
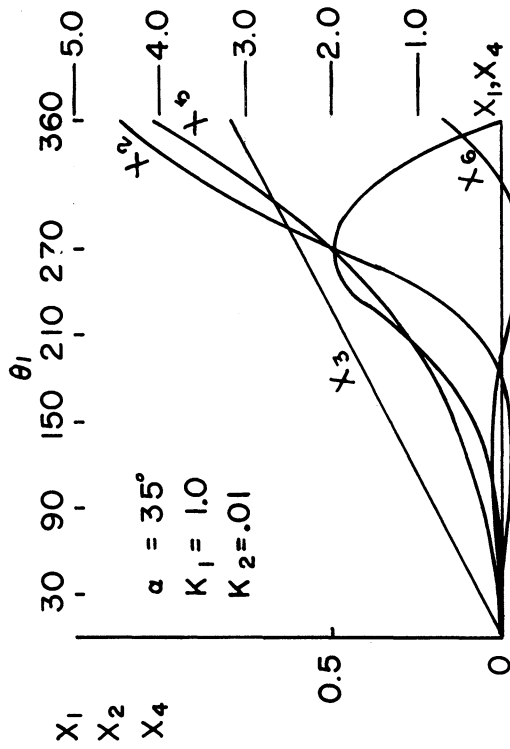
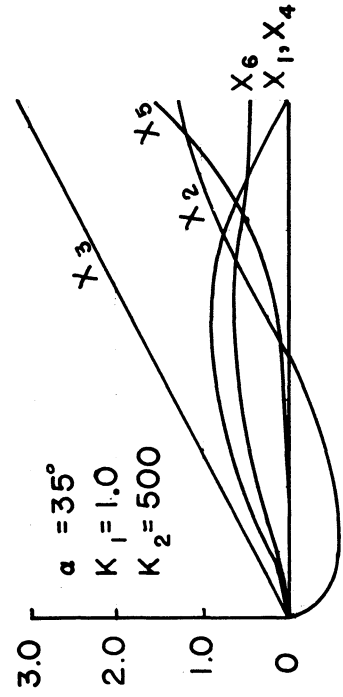
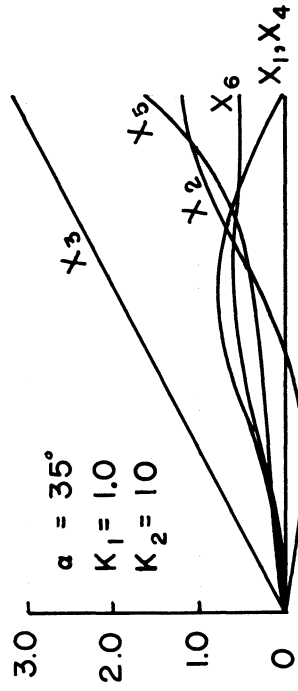
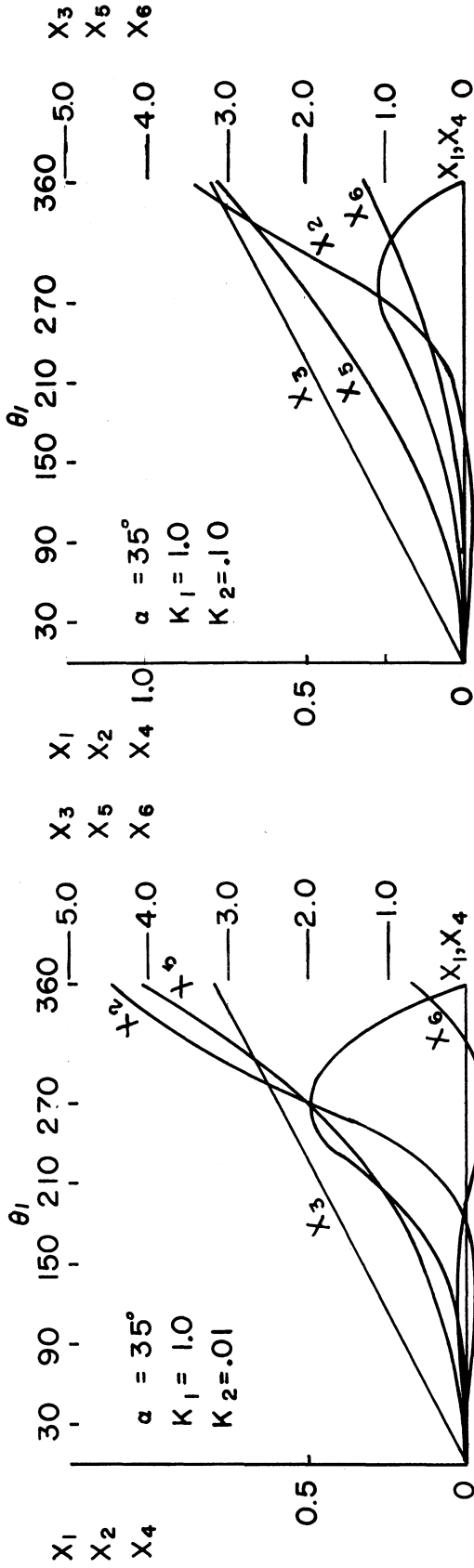

DESIGN CHARTS (CONT'D)

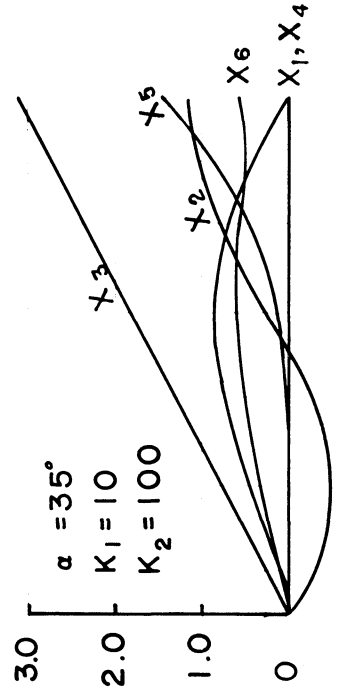
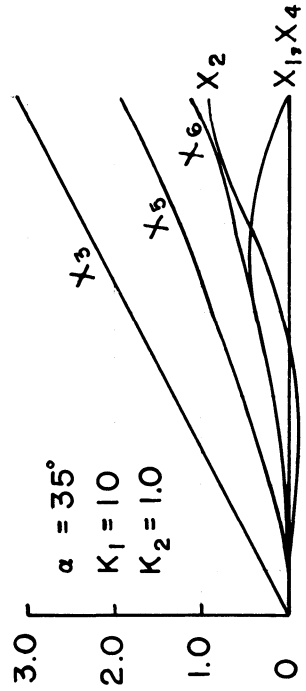
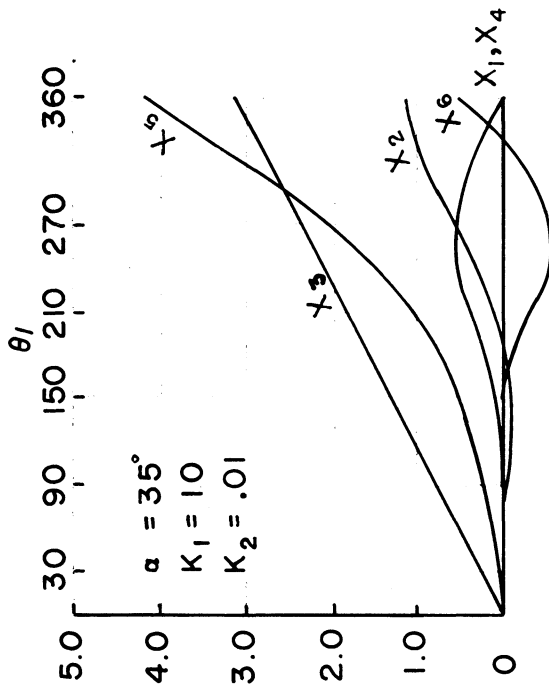
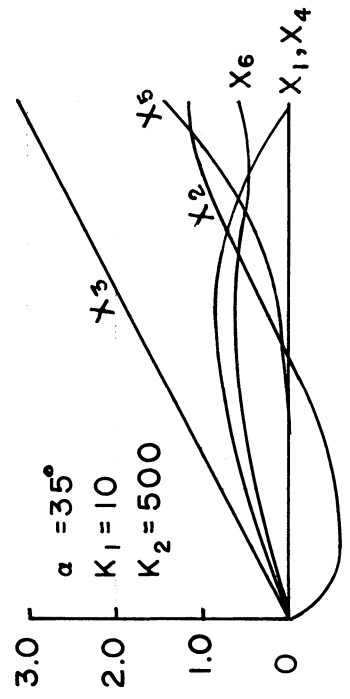
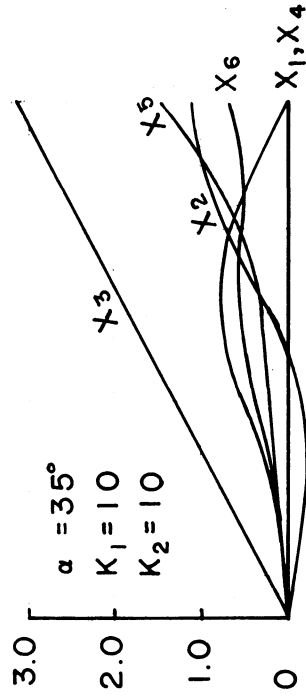
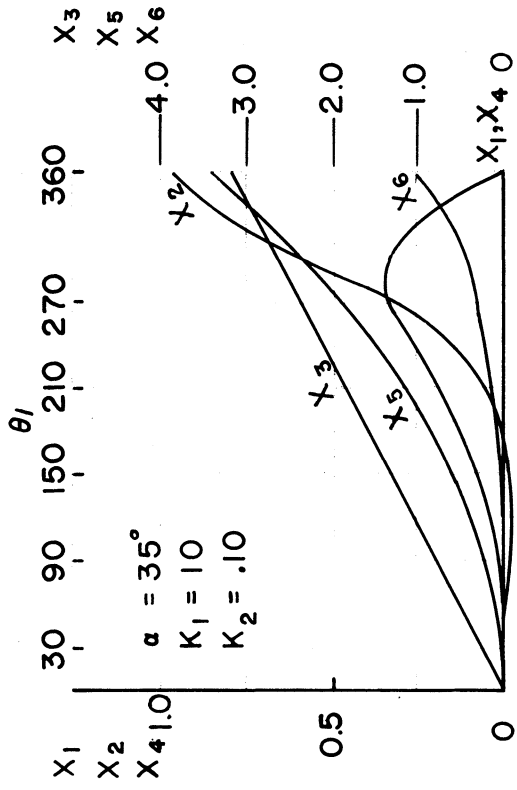

DESIGN CHARTS (CONT'D)

